

FOTOCERAMICHEVASIURNE

POLISTAMPA

CATALOGO
GENERALE

indice - index

L'esigenza di creare un Catalogo Generale, nasce dalla crescente offerta di prodotti che Polistampa ha introdotto nel tempo. Il nuovo Catalogo Generale racchiude tutta la nostra produzione tranne il prodotto Lapidi presentato su un catalogo dedicato. Siamo certi che questo nuovo strumento faciliterà l'orientamento e la scelta del cliente.

Nello sviluppo di questo Catalogo Generale, arricchito da una rinnovata linea di prodotti, abbiamo indirizzato la nostra ricerca verso quelle soluzioni che si contraddistinguono sul mercato proprio per il loro carattere sobrio, per l'uso di un segno misurato e delicato; questo perché crediamo che un linguaggio puro e semplice sia quello giusto perché capace, più di ogni altro, di lasciare spazio e dare voce al silenzio.

Tra le novità che la Polistampa è lieta di presentare, quella che più di ogni altra traccia le linee del nuovo percorso stilistico intrapreso, è sicuramente la "Collezione Design", una collezione di prodotti unica, nata dalla collaborazione della nostra Azienda con il Designer Luca Cimarra.

Altra novità di rilievo che colloca la nostra Azienda tra le prime al mondo per capacità tecniche e produttive è la "Fotoceramica Tridimensionale", una lavorazione su due livelli che rompe la staticità della fotoceramica tradizionale creando un effetto di profondità che suscita una sensazione di vicinanza e di contatto con la persona amata.

The need to create a general catalogue, arises from the increasing range of products that Polistampa introduced over time. The new General Catalogue encompasses all our production except the product presented on a catalog Gravestones dedicated. We are confident that this new instrument will facilitate the orientation and customer choice.

In developing this General Catalogue, enriched by a renewed product line, we have directed our research towards those solutions that are distinguished in the market because of their sober character, for the use of a measured and delicate sign; this because we believe that a pure and simple language is the right one because capable, to leave space and give voice to silence, more than any other.

Among the most important news that Polistampa is pleased to announce that more than any other traces the lines of new stylistic direction taken, is definitely the "Design Collection", a collection of unique products, born from the collaboration of our company with Designer Luca Cimarra.

Other innovations that places our company among the top in the world for technical and production capacity is the "Three-dimensional" Fotoceramica, a machining on two levels that breaks the traditional static fotoceramica by creating an appearance of depth that evokes a feeling of closeness and contact with the loved one.

pag. 2 - Collezione Design - Design Collection

pag. 20 - Fotoceramiche - Photoceramics

" 20	FotoDecoro - <i>DecorPhoto</i>
" 27	Fotoceramiche standard - <i>Standard photoceramics</i>
" 42	Croce con foto - <i>Cross with photo</i>
" 43	Boemia - <i>Bohemia</i>
" 45	Fotorilievi - <i>Photoreliefs</i>
" 48	Fotominiature e Pendenti - <i>Photominiatures and Pendants</i>
" 49	Calamite e portachiavi con miniatura - <i>Magnets and key-rings with miniature</i>
" 50	Fotoceramiche 3D - <i>3D Photoceramics</i>
" 56	Targhe a parete - <i>Wall Plaques</i>
" 78	Libri a parete - <i>Wall Books</i>
" 88	Pergamene a parete - <i>Wall Parchments</i>
" 101	FotoMarmo (spessore 2 cm) - <i>PhotoStone (thickness cm 2)</i>
" 104	Supporti a terreno per ceramiche - <i>Ground Supports for ceramics</i>
" 105	Fotolapidi in Porcellana - <i>Porcelain Tombstone</i>
" 108	Porcellane a terreno - <i>Ground Porcelains</i>
" 123	Articoli in Cristallo *Diamante - <i>Crystal Articles *Diamant</i>
" 130	Stampe e Ricordini - <i>Prints and Remembrancers</i>
" 138	Fondi - <i>Backgrounds</i>
" 146	Abiti - <i>Clothes</i>
" 150	Scelta Immagini Sacre e Floreali - <i>Available Sacred and Floreal Images</i>
" 156	Dediche - <i>Dedications</i>
" 158	Caratteri - <i>Text types</i>

pag. 160 - Accessori in porcellana - Porcelain Accessories

" 162	Linea Dune - <i>Dune Line</i>
" 164	Linea Flora - <i>Flora Line</i>
" 167	Linea Park - <i>Park Line</i>
" 170	Linea Camelia - <i>Camelia Line</i>
" 173	Linea Garden - <i>Garden Line</i>
" 176	Linea Dalia - <i>Dalia Line</i>
" 179	Linea Ninfea - <i>Ninfea Line</i>
" 182	Lettere ed Immagini in Porcellana - <i>Porcelain Letters and Images</i>
" 183	Decorazioni disponibili (marmi, graniti, rilievi) - <i>Available Decorations (marbles, granits, reliefs)</i>
" 184	Fiamme in Cristallo ed Interni inox - <i>Crystal Flames and inox container</i>

pag. 186 - Urne in porcellana - Porcelain Urnes

" 187	Linea Liberty - <i>Liberty Line</i>
" 190	Linea Sfera - <i>Sfera Line</i>
" 193	Linea Classica - <i>Classic Line</i>
" 196	Linea Esagono - <i>Hexagon Line</i>
" 199	Urne con simboli e personalizzate - <i>Personalized and with symbols urns</i>

DESIGN COLLECTION

COLLEZIONE DESIGN

La **Collezione Design** è frutto della collaborazione con l'affermato designer Luca Cimarra che ha coniugato un gusto ed uno stile "nuovo" con le esigenze del mercato. I prodotti nati da questa collaborazione rappresentano per il settore l'espressione massima in stile e design.

Tutti i modelli e le decorazioni di questa collezione, di proprietà del Designer e di Polistampa, sono stati depositati.

*The **Collection Design** is the result of collaboration with the already affermed designer Luca Cimarra that conjugates style and design defined "new" in market requirements. The products born from this collaboration are rapresented for this sector in maximum expression in style and design.*

All models and decorations of this collection,are trademarks of the Designer and Polistampa.





Am01

Targa Onde - Onde Plaque

Articolo - Item

Misure - Size

ONDE

cm 29 x 36

Questo articolo può essere richiesto sia in versione orizzontale che verticale
This article can be ordered in horizontal or vertical version

Il prodotto è equipaggiato con perni sul retro per il montaggio
The product is equipped with screws on the back to be fixed



Dettaglio in prospettiva della targa
View of the plaque



Am01



Am02



Am03



Am04



Am05



Am06



Am07



Am08



Am09



Am10



Am11



Am12

Collezione Design

Targa Segno - Segno Plaque

Articolo - Item

Misure -Size

SEGNO

cm 28 x 35

Il prodotto è equipaggiato con perni sul retro per il montaggio
The product is equipped with screws on the back to be fixed



Am13



Dettaglio in prospettiva della targa
View of the plaque

Collezione Design

Targa **Segno**

Modelli Depositati



Am14



Am15



Am16



Am17

Collezione Design



Am18



Am19



Am20



Am21



Am22



Am23



Am24



Am25

Libro Ricordi - Ricordi Book

Articolo - Item

Misure -Size

RICORDI

cm 29 x 36

Il prodotto è equipaggiato con perni sul retro per il montaggio
The product is equipped with screws on the back to be fixed



Am26



Dettaglio in prospettiva del libro
View of the book

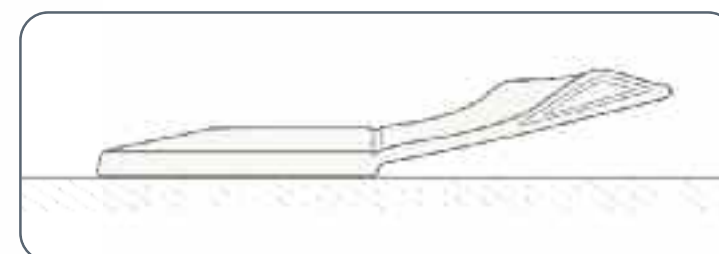

Prospettiva che evidenzia la pagina destra del libro rialzata
View of the book that show the right page raised

Collezione Design

Libro **Ricordi**

Modelli Depositati



Am27



Am28



Am29



Am30



Am31



Am32



Am33



Am34



Am35



Am36



Am37



Am38

Targa Foglio - Foglio Plaque

Articolo - Item

Misure -Size

FOGLIO

cm 29 x 36

Il prodotto è equipaggiato con perni sul retro per il montaggio
The product is equipped with screws on the back to be fixed



Am39



Dettaglio in prospettiva della pergamena
View of the parchment



Am40



Am41



Am42



Am43

Collezione Design



Am44



Am45



Am46



Am47



Am48



Am49



Am50



Am51

Collezione Design

FotoDecoro, esercizio di stile e sobrietà delle forme. Unico pezzo dove i confini tra foto e cornice si mescolano nella decorazione grafica.

***FotoDecoro**, exercise of style and sobriety of the shapes. Single piece where the boundaries between photo and frame mingle in graphic decoration.*

DECORPHOTOES

FOTODECORI

FotoDecoro Ovale - Oval Decorphoto

Articolo - Item	Misura Foto - Photo Size	Misura Pezzo - Piece Size
FDO12	cm 7,5 x 10	cm 12 x 14,5
FDO15	cm 10 x 13	cm 15 x 18

Questo articolo può essere richiesto sia in versione lucida che opaca
This article can be ordered in glossy or mat version

Il prodotto è equipaggiato con perni sul retro per il montaggio
The product is equipped with screws on the back to be fixed



Dettaglio in prospettiva della ceramica
View of the ceramic



Am52

Decorazioni oro, argento e pietra *Gold, silver and stone decorations*



Oro - Gold



Argento - Silver



Decorato - Decorated

Marmorizzazioni disponibili a pag. 183
Available stone decorations on page 183

Fotoceramiche



Am53



Am54



Am55



Am56



Am57

Fotoceramiche

FotoDecoro Ovale

Modelli Depositati



Am58



Am59



Am60



Am61



Am62

Fotoceramiche



Am63

FotoDecoro Rettangolare - Rectangular Decorphoto

Articolo - Item	Misura Foto - Photo Size	Misura Pezzo - Piece Size
FDR12	cm 8,5 x 11,5	cm 12,5 x 16

Questo articolo può essere richiesto sia in versione lucida che opaca
This article can be ordered in glossy or mat version

Il prodotto è equipaggiato con perni sul retro per il montaggio
The product is equipped with screws on the back to be fixed



Dettaglio in prospettiva della ceramica
View of the ceramic

Decorazioni oro, argento e pietra *Gold, silver and stone decorations*



Oro - Gold



Argento - Silver



Decorato - Decorated

Marmorizzazioni disponibili a pag. 183
Available stone decorations on page 183

Fotoceramiche

FotoDecoro Rettangolare

Modelli Depositati



Am64



Am65



Am66



Am67



Am68

Fotoceramiche



Am69



Am70



Am71



Am72



Am73

La Polistampa amplia la propria offerta di fotoceramiche introducendo una nuova linea di prodotti che vanno ad arricchire la già vasta gamma "**BestColor**". Il nuovo percorso stilistico si evidenzia anche nelle fotoceramiche tradizionali proposte nelle versioni "**Ambiente**"; l'inserimento dell'immagine in un contesto grafico trasforma la semplice fotoceramica in un oggetto di assoluta eleganza.

Polistampa extends its offer of photoceramics by introducing a new line of products that enriches the already wide range "BestColor". The new stylistic direction highlights even the traditional photoceramic proposed in versions "Ambiente"; inserting the image in a graphic context transforms a simple photoceramic into an object of absolute elegance.

PHOTOCERAMICS

FOTOCERAMICHE



Ovale - Oval

Articolo - Item		Misure -Size
Colori	Bianco/Nero	cm
O4	O4BN	4 x 6
O5	O5BN	5 x 7
O6	O6BN	6 x 8
O7	O7BN	7 x 9
O8	O8BN	8 x 10
O9	O9BN	9 x 12
O10	O10BN	10 x 13
O11	O11BN	11 x 15
O13	O13BN	13 x 18
O18	O18BN	18 x 24
O24	O24BN	24 x 30
O30	O30BN	30 x 40
O40	O40BN	40 x 60
O50	O50BN	50 x 70

Per la colorazione Seppia aggiungere "SEPIA" al codice dei colori
 For Sepia Colour add "SEPIA" to the colour Item

Placca spessore 8 mm con viti *Plaque thickness mm 8, with screws*

Misura - Size	cm	7 x 9
Misura - Size	cm	8 x 10
Misura - Size	cm	9 x 12
Misura - Size	cm	11 x 15
Misura - Size	cm	13 x 18



Decorazioni oro e argento - *Gold and silver decorations*



Oro - Gold	Or1 Filo staccato	Or2 Bordo	Or3 Filo+Bordo	Or5 Filo attaccato
Argento - Silver	Ar1 Filo staccato	Ar2 Bordo	Ar3 Filo+Bordo	Ar5 Filo attaccato

Fotoceramiche

Ovale

Particolari ambientazioni disponibili per le ceramiche ovali
Particular available decorations for oval ceramics



Am74



Am75



Am76



Am77



Am78



Am79



Am80



Am81

Fotoceramiche

Ovale **Ambiente**



Rettangolare - Rectangular

Articolo - Item		Misure - Size
Colori	Bianco/Nero	cm
R5	R5BN	5 x 7
R6	R6BN	6 x 8
R7	R7BN	7 x 9
R8	R8BN	8 x 10
R9	R9BN	9 x 12
R10	R10BN	10 x 15
R11	R11BN	11 x 15
R13	R13BN	13 x 18
R18	R18BN	18 x 24
R24	R24BN	24 x 30
R30	R30BN	30 x 40
R40	R40BN	40 x 60
R50	R50BN	50 x 70

Per la colorazione Seppia aggiungere "SEPIA" al codice dei colori
 For Sepia Colour add "SEPIA" to the colour Item

Placca spessore 8 mm con viti *Plaque thickness mm 8, with screws*

Misura - Size	cm	7 x 9
Misura - Size	cm	8 x 10
Misura - Size	cm	9 x 12
Misura - Size	cm	11 x 15
Misura - Size	cm	13 x 18



Decorazioni oro e argento - Gold and silver decorations



Oro - Gold

Or1 Filo staccato

Or2 Bordo

Or3 Filo+Bordo

Or5 Filo attaccato

Argento - Silver

Ar1 Filo staccato

Ar2 Bordo

Ar3 Filo+Bordo

Ar5 Filo attaccato

Fotoceramiche

Rettangolare

Particolari ambientazioni disponibili per le ceramiche rettangolari
Particular available decorations for rectangular ceramics



Am82



Am83



Am84



Am85



Am86



Am87

Fotoceramiche

Rettangolare **Ambiente**



Tondo - Round

Articolo - Item		Misure -Size
Colori	Bianco/Nero	cm
T6	T6BN	6
T7	T7BN	7
T8	T8BN	8
T9	T9BN	9
T10	T10BN	10
T12	T12BN	12
T15	T15BN	15
T16	T16BN	16
T18	T18BN	18
T20	T20BN	20
T25	T25BN	25
T30	T30BN	30
T40	T40BN	40
T50	T50BN	50

Per la colorazione Seppia aggiungere "SEPIA" al codice dei colori
 For Sepia Colour add "SEPIA" to the colour Item

Decorazioni oro e argento - Gold and silver decorations



Fotoceramiche

Oro - Gold

Or1 Filo staccato

Or2 Bordo

Or3 Filo+Bordo

Or5 Filo attaccato

Argento - Silver

Ar1 Filo staccato

Ar2 Bordo

Ar3 Filo+Bordo

Ar5 Filo attaccato

Tondo

Particolari ambientazioni disponibili per le ceramiche tonde
Particular available decorations for round ceramics



Am88



Am89



Am90



Am91



Am92



Am93

Fotoceramiche

Tondo **Ambiente**



Quadrato - Square

Articolo - Item		Misure -Size
Colori	Bianco/Nero	cm
Q5	Q5BN	5 x 5
Q10	Q10BN	10 x 10
Q15	Q15BN	15 x 15
Q20	Q20BN	20 x 20
Q30	Q30BN	30 x 30
Q40	Q40BN	40 x 40
Q50	Q50BN	50 x 50

Per la colorazione Seppia aggiungere "SEPIA" al codice dei colori
 For Sepia Colour add "SEPIA" to the colour Item

Decorazioni oro e argento - Gold and silver decorations



Fotoceramiche

Oro - Gold

Or1 Filo staccato

Or2 Bordo

Or3 Filo+Bordo

Or5 Filo attaccato

Argento - Silver

Ar1 Filo staccato

Ar2 Bordo

Ar3 Filo+Bordo

Ar5 Filo attaccato

Quadrato

Particolari ambientazioni disponibili per le ceramiche quadrate
Particular available decorations for square ceramics



Am94



Am95



Am96



Am97



Am98



Am99

Fotoceramiche

Quadrato **Ambiente**



Cuore - Heart

Articolo - Item		Misure -Size
Colori	Bianco/Nero	cm
CU6	CU6BN	6 x 6
CU8	CU8BN	8 x 8
CU10	CU10BN	10 x 10
CU12	CU12BN	12 x 12
CU15	CU15BN	15 x 15
CU20	CU20BN	20 x 20
CU25	CU25BN	25 x 25
CU30	CU30BN	30 x 30
CU40	CU40BN	40 x 40
CU50	CU50BN	50 x 50

Per la colorazione Seppia aggiungere "SEPIA" al codice dei colori
 For Sepia Colour add "SEPIA" to the colour Item

Decorazioni oro e argento - Gold and silver decorations



Oro - Gold	Or1 Filo staccato	Or2 Bordo	Or3 Filo+Bordo	Or5 Filo attaccato
Argento - Silver	Ar1 Filo staccato	Ar2 Bordo	Ar3 Filo+Bordo	Ar5 Filo attaccato

Fotoceramiche

Cuore

Particolari ambientazioni disponibili per le ceramiche cuore
Particular available decorations for heart ceramics



Am100



Am101



Am102



Am103



Am104



Am105

Fotoceramiche

Cuore **Ambiente**



Am106



Am107



Am108



Am109



Am110



Am111

Composizione Cuore Doppio - Double Heart

Articolo - Item	Misure -Size
CUBIS destro	cm 22 x 18
CUBIS sinistro	cm 22 x 18

Particolari ambientazioni disponibili per le ceramiche cuore doppio
Particular available decorations for double heart ceramics

Fotoceramiche

Cuore Doppio

Le decorazioni sopra esposte possono essere realizzate sia per i modelli con cuore destro che per quelli con cuore sinistro.
We can realize the decorations showed for both models; the right one and the left one.

Su richiesta, è possibile realizzare soluzioni personalizzate.
On demand, we can realize personalized solutions.



Am112

Composizione Cuore Triplo - Triple Heart

Articolo - Item	Misure - Size
CUTRIS	cm 28 x 18

Particolari ambientazioni disponibili per le ceramiche cuore triplo
Particular available decorations for triple heart ceramics



Am113



Am114



Am115

Fotoceramiche

Su richiesta, è possibile realizzare soluzioni personalizzate.
On demand, we can realize personalized solutions.

Cuore Triplo



Am116



Am117



Am118



Am119

Cupola - Cupola

Articolo - Item		Misure -Size
Colori	Bianco/Nero	cm
CUP9	CUP9BN	9 x 12
CUP12	CUP12BN	12 x 16
CUP18	CUP18BN	18 x 24
CUP20	CUP20BN	20 x 30
CUP25	CUP25BN	25 x 40
CUP30	CUP30BN	30 x 50
CUP40	CUP40BN	40 x 60

Particolari ambientazioni disponibili per le ceramiche cupola
Particular available decorations for cupola ceramics



Am120

Fotoceramiche

Cupola **Ambiente**

Su richiesta, è possibile realizzare soluzioni personalizzate.
On demand, we can realize personalized solutions.



Am121



Am122



Am123



Am124



Am125



Am126

Fotoceramiche

Cupola **Ambiente**



Am127

FotoCroce - PhotoCross

Articolo - Item

Misure - Size

CROS18

cm 18 x 24

Particolari ambientazioni disponibili per le ceramiche croce
Particular available decorations for cross ceramics

Il prodotto è equipaggiato con perni sul retro per il montaggio
The product is equipped with screws on the back to be fixed



Am128



M6 Rosa Portogallo



M1 Travertino

Croce Marmorizzata - Decorated Cross

Marmorizzazioni disponibili a pag. 183
Available stone decorations on page 183

Immagini Sacre disponibili a pag. 150
Available Sacred Images on page 150

Fotoceramiche

FotoCroce

Su richiesta, è possibile realizzare soluzioni personalizzate.
On demand, we can realize personalized solutions.

Boemia - Bohemia

Articolo - Item		Misure - Size
Colori	Bianco/Nero	cm
B7	B7BN	7 x 9
B8	B8BN	8 x 10
B9	B9BN	9 x 11
B11	B11BN	11 x 14
B14	B14BN	14 x 16
B16	B16BN	16 x 19
B18	B18BN	18 x 22

Per la colorazione Seppia aggiungere "SEPIA" al codice dei colori
 For Sepia Colour add "SEPIA" to the colour Item



Decorazioni oro e argento *Gold and silver decorations*



Oro - Gold

Or1 Filo

Or2 Bordo

Or3 Filo+Bordo

Or4 Doppio Filo

Argento - Silver

Ar1 Filo

Ar2 Bordo

Ar3 Filo+Bordo

Ar4 Doppio Filo

Fotoceramiche

Boemia



M1 Travertino

Boemia Decorata - *Decorated Bohemia*

Articolo - *Item*

Misure - *Size*

Colori	Bianco/Nero	cm
BD7	BD7BN	7 x 9
BD8	BD8BN	8 x 10
BD9	BD9BN	9 x 11
BD11	BD11BN	11 x 14
BD14	BD14BN	14 x 16
BD16	BD16BN	16 x 19
BD18	BD18BN	18 x 22



M2 Carrara



M3 Verde Alpi



M4 Botticino



M5 Nero Africa



M6 Rosa Portogallo



M7 Rosa Beta

Fotoceramiche

Boemia Decorata

Decorazioni disponibili per i bordi dei Boemia a pag. 183
Available border decorations for the Bohemia on page 183

Fotorilievo Donatello - Donatello Photorelief

Articolo - Item	Misura Foto - Photo Size	Misura Pezzo - Piece Size
DON9	cm 9 x 12	cm 12 x 15
DON11	cm 11 x 15	cm 15 x 18

Il prodotto è equipaggiato con perni sul retro per il montaggio
 The product is equipped with screws on the back to be fixed



Bianco - White



Oro - Gold



M1 Travertino



M2 Carrara



M4 Botticino



M5 Nero Africa



M6 Rosa Portogallo

Fotorilievi



Bianco - White

Fotorilievo Michelangelo - *Michelangelo Photorelief*

Articolo - Item	Misura Foto - Photo Size	Misura Pezzo - Piece Size
MIC9	cm 9 x 12	cm 13 x 18
MIC11	cm 11 x 15	cm 17 x 23

Il prodotto è equipaggiato con perni sul retro per il montaggio
 The product is equipped with screws on the back to be fixed



Oro - Gold



M1 Travertino



M2 Carrara



M4 Botticino



M5 Nero Africa



M6 Rosa Portogallo

Fotorilievi

Michelangelo

Decorazioni disponibili per i bordi dei Fotorilievi a pag. 183
 Available border decorations for the Photoreliefs on page 183

Fotorilievo Cellini - Cellini Photorelief

Articolo - Item	Misura Foto - Photo Size	Misura Pezzo - Piece Size
CEL9	cm 9 x 12	cm 15 x 20
CEL11	cm 11 x 15	cm 17 x 22

Il prodotto è equipaggiato con perni sul retro per il montaggio
 The product is equipped with screws on the back to be fixed



Bianco - White



Oro - Gold



M1 Travertino



M2 Carrara



M4 Botticino



M5 Nero Africa



M6 Rosa Portogallo

Fotorilievi

Decorazioni disponibili per i bordi dei Fotorilievi a pag. 183
 Available border decorations for the Photoreliefs on page 183

Cellini

Fotominiatura - Photominiature

Articolo - Item

Colori Bianco/Nero

MIN MINBN

Il codice è uguale per qualsiasi formato e misura - Same code for any shape and size

Per la colorazione Seppia aggiungere "SEPIA" al codice dei colori - For Sepia Colour add "SEPIA" to the colour Item



Fotominiatura Ovale

Oval Photominiature

Misure - Size

mm 13 x 18
mm 16 x 20
mm 18 x 24
mm 19 x 25
mm 20 x 27
mm 21 x 29
mm 24 x 30
mm 25 x 35
mm 20 x 38
mm 20 x 45
mm 30 x 40
mm 35 x 45



Fotominiatura Tonda

Round Photominiature

Misure - Size

mm 14
mm 16
mm 18
mm 19
mm 20
mm 22
mm 24
mm 27
mm 30
mm 40



Fotominiatura Cuore

Heart Photominiature

Misure - Size

mm 15
mm 20
mm 25
mm 30



Fotominiatura Quadrato

Square Photominiature

Misure - Size

mm 22
mm 24
mm 26
mm 30



Fotominiatura Rettangolare

Rectangular Photominiature

Misure - Size

mm 20 x 58
mm 30 x 40

Pendenti per Fotominiature - Pendants for Photominiature

Le misure sono riferite alle miniature inserite nei pendenti - The sizes are referred to the miniatures on the pendants



Ovale Oro puro

Pure gold Oval

Art. - Item Misure - Size

Pe10 mm 20 x 27
Pe11 mm 24 x 30



Goccia Argento

Silver Drop

Art. - Item Misure - Size

Pe14 mm 18 x 24



Ovale Metallo Dorato

Golden Oval

Art. - Item Misure - Size

Pe16 mm 13 x 19



Cuore Metallo Dorato

Golden Heart

Art. - Item Misure - Size

Pe18 mm 15



Tondo Oro puro

Pure gold Round

Art. - Item Misure - Size

Pe12 mm 22
Pe13 mm 27



Tondo Argento

Silver Round

Art. - Item Misure - Size

Pe15 mm 19



Ovale Metallo Argentato

Silvered Oval

Art. - Item Misure - Size

Pe17 mm 13 x 19



Cuore Metallo Argentato

Silvered Heart

Art. - Item Misure - Size

Pe19 mm 15

Calamite in metallo con miniatura - Metal Magnet with miniature

Le misure sono riferite alle miniature inserite nelle calamite - The sizes are referred to the miniatures on the magnets



Tondo Argentato
Silvered Round

Art. - Item Misure - Size
Cal20 mm 25



Tondo Dorato
Golden Round

Art. - Item Misure - Size
Cal21 mm 16



Cuore Argentato
Silvered Heart

Art. - Item Misure - Size
Cal24 mm 15



Ovale Dorato
Golden Oval

Art. - Item Misure - Size
Cal22 mm 13 x 19



Ovale Argentato
Silvered Oval

Art. - Item Misure - Size
Cal23 mm 24 x 32



Rettangolare in Resina
Resin Rectangular

Art. - Item Misure - Size
Cal25 mm 35 x 55
Cal26 mm 35 x 85

Portachiavi in metallo con miniatura - Metal Key-ring with miniature

Le misure sono riferite alle miniature inserite nei portachiave - The sizes are referred to the miniatures on the key-rings

Legno - Wood

Doppia miniatura
Double miniature



Tondo lavorato argentato
Worked silvered round

Art. - Item Misure - Size
Por27 mm 21 (x2)

Doppia miniatura
Double miniature



Tondo lucido argentato
Silvered round

Art. - Item Misure - Size
Por28 mm 21 (x2)

Doppia miniatura
Double miniature



Tondo lucido oro
Golden round

Art. - Item Misure - Size
Por29 mm 21 (x2)



Cuore chiuso
Closed heart

Art. - Item Misure - Size
Por30 mm 15



Rosa chiusa
Closed rose

Art. - Item Misure - Size
Por31 mm 21

Doppia miniatura
Double miniature



Tondo Legno
Wood Round

Art. - Item Misure - Size
Por32 mm 21 (x2)

Le Fotoceramiche **3D** sono un prodotto rivoluzionario in quanto rompono gli schemi con la classica fotoceramica mettendo il soggetto in risalto con un effetto tridimensionale dato dalla lavorazione personalizzata su più livelli della placca. Oltre che su placche ovali e rettangolari, la lavorazione tridimensionale viene applicata anche su libri e pergamene di varie misure.

*The **3D** Photoceramics are a revolutionary product as they break schemas with the classical photoceramic putting your subject in stand out with a three-dimensional effect given by crafting custom layered plaque. Other than on oval and rectangular plaques, the three-dimensional processing is also applied on books and parchments of various measures.*

3D PHOTOCERAMICS
OutLine

FOTOCERAMICHE 3D

OutLine



Rettangolare 3D - 3D Rectangular

Articolo - Item	Misure -Size
3DR7	cm 7 x 9
3DR8	cm 8 x 10
3DR9	cm 9 x 12
3DR11	cm 11 x 15
3DR13	cm 13 x 18
3DR18	cm 18 x 24



Dettaglio della ceramica sezionata
View of the ceramic cut up



Ovale 3D - 3D Oval

Articolo - Item	Misure - Size
3DO7	cm 7 x 9
3DO8	cm 8 x 10
3DO9	cm 9 x 12
3DO11	cm 11 x 15
3DO13	cm 13 x 18
3DO18	cm 18 x 24



Dettaglio della ceramica sezionata
View of the ceramic cut up



Foto della persona e Fiori in rilievo

Am129

Libro 3D - 3D Book

Articolo - Item	Misure -Size
3DL21	cm 21 x 15
3DL23	cm 23 x 20
3DL29	cm 29 x 23

Il prodotto è equipaggiato con perni sul retro per il montaggio
The product is equipped with screws on the back to be fixed



Foto della persona e Fiori in rilievo

Am130



Foto della persona e Fiori in rilievo

Am131



Foto della persona e Fiori in rilievo

Am132

Outline Prodotto Brevettato

Su richiesta, è possibile realizzare soluzioni personalizzate.
On demand, we can realize personalized solutions.

Fotoceramiche 3D

Libro 3D



Am133

Foto della persona e Immagine Sacra in rilievo



Am134

Foto della persona e Disegno in rilievo



Am135

Foto della persona e Immagine Sacra in rilievo



Am136

Foto della persona e Immagine Sacra in rilievo

Pergamena 3D - 3D Parchment

Articolo - Item	Misure -Size
3DP11	cm 11 x 20
3DP13	cm 13 x 26
3DP18	cm 18 x 37

Il prodotto è equipaggiato con perni sul retro per il montaggio
 The product is equipped with screws on the back to be fixed



Foto della persona e Immagine Sacra in rilievo

Am137



Foto della persona e Disegno in rilievo

Am138



Foto della persona e Fiori in rilievo

Am139

OutLine Prodotto Brevettato

Su richiesta, è possibile realizzare soluzioni personalizzate.
 On demand, we can realize personalized solutions.

Fotoceramiche 3D

Pergamena **3D**

L'originale linea di targhe a parete (Giotto - Bernini - Canova) realizzate in fine porcellana, unisce in un unico pezzo, l'immagine a grandi dimensioni con i dati del proprio caro o con una dedica.

Presentiamo inoltre una nuova collezione di tre targhe (Monet - Cézanne - Renoir), studiate appositamente per l'inserimento di epigrafi e/o dediche.

Oltre all'eleganza delle varie soluzioni grafiche che impreziosiscono le scritte, il vantaggio di queste **Targhe con Epigrafe**, rispetto ai tradizionali sistemi di scrittura (lettere di vari materiali o incisione), è rappresentato dalla facilità del montaggio.

The original line of wall plaques (Giotto-Bernini-Canova) made of thin porcelain, combines in one piece, the large image with the details of their dear or with a dedication.

*We also present a new collection of three plaques (Monet-Cézanne-Renoir), specially studied for inserting epigraphs and/or dedications. In addition to the elegance of the various graphics solutions that embellish the written, the advantage of these **Plaques with Inscriptions**, from traditional writing systems (letters of various materials or engraving), is ease in the mounting.*

WALL PLAQUES

TARGHE A PARETE



Am140

Il prodotto è equipaggiato con perni sul retro per il montaggio
 The product is equipped with screws on the back to be fixed

Targa Giotto - Giotto wall Plaque

Articolo - Item	Misure -Size
TG30	cm 30 x 41
TG24	cm 24 x 30



Targa Giotto con bordo decorato

Giotto wall plaque with decorated border

Articolo - Item	Misure -Size
TGM30	cm 30 x 41
TGM24	cm 24 x 30

Marmorizzazioni disponibili a pag. 183
 Available stone decorations on page 183

Targhe a Parete

Su richiesta, è possibile realizzare soluzioni personalizzate.
 On demand, we can realize personalized solutions.

Targa **Giotto**



Am141



Am142



Am143



Am144



Am145



Am146

Targhe a Parete

Targa **Giotto**



Am147



Am148



Am149



Am150



Am151



Am152

Targhe a Parete

Targa **Giotto**



Am153



Am154



Am155



Am156



Bianco - White



Decorato - Decorated

Marmorizzazioni disponibili a pag. 183
Available stone decorations on page 183

Targa Giotto solo Scritta

Giotto wall plaque only with writings

Articolo - Item		Misure - Size
Bianco	Decorato	cm
TGD30	TGDM30	30 x 41
TGD24	TGDM24	24 x 30

E' possibile inserire scritte con qualsiasi carattere (vedi pag. 158)
Il colore delle scritte può essere nero o grigio
It's possible to put any text types (see page 158)
The colour of the writings can be black or grey

Targhe a Parete

Targa **Giotto**



Am157

Il prodotto è equipaggiato con perni sul retro per il montaggio
 The product is equipped with screws on the back to be fixed



Targa Bernini con bordo decorato
Bernini Plaque with decorated border

Articolo - Item	Misure -Size
TBM30	cm 30 x 41
TBM24	cm 24 x 30

Marmorizzazioni disponibili a pag. 183
 Available stone decorations on page 183

Targhe a Parete

Su richiesta, è possibile realizzare soluzioni personalizzate.
 On demand, we can realize personalized solutions.

Targa **Bernini**



Am158



Am159



Am160



Am161



Am162



Am163

Targhe a Parete

Targa **Bernini**



Am164



Am165



Am166



Am167



Am168



Am169

Targhe a Parete

Targa **Bernini**



Am170



Am171



Am172



Am173



Am174



Am175

Targhe a Parete

Targa **Bernini**



Am176



Am177



Am178



Am179



Bianco - White



Decorato - Decorated

Marmorizzazioni disponibili a pag. 183
Available stone decorations on page 183

Targa Bernini solo Scritta

Bernini wall plaque only with writings

Articolo - Item		Misure - Size
Bianco	Decorato	cm
TBD30	TBDM30	30 x 41
TBD24	TBDM24	24 x 30

E' possibile inserire scritte con qualsiasi carattere (vedi pag. 158)
Il colore delle scritte può essere nero o grigio
It's possible to put any text types (see page 158)
The colour of the writings can be black or grey

Targhe a Parete

Targa **Bernini**



Am180

Targa Canova - Canova wall Plaque

Articolo - Item	Misure -Size
TC32	cm 32 x 40
TC25	cm 25 x 30

Il prodotto è equipaggiato con perni sul retro per il montaggio
The product is equipped with screws on the back to be fixed



Targa Canova con bordo decorato

Canova Plaque with decorated border

Articolo - Item	Misure -Size
TCM32	cm 32 x 40
TCM25	cm 25 x 30

Marmorizzazioni disponibili a pag. 183
Available stone decorations on page 183

Targhe a Parete

Targa **Canova**

Su richiesta, è possibile realizzare soluzioni personalizzate.
On demand, we can realize personalized solutions.



Am181



Am182



Am183



Am184



Am185



Am186

Targhe a Parete

Targa **Canova**



Am187



Am188



Am189



Am190



Am191



Am192

Targhe a Parete

Targa **Canova**



Am193



Am194



Am195



Am196



Bianco - White



Decorato - Decorated

Marmorizzazioni disponibili a pag. 183
Available stone decorations on page 183

Targa Canova solo Scritta

Canova wall plaque only with writings

Articolo - Item		Misure - Size
Bianco	Decorato	cm
TCD32	TCDM32	32 x 40
TCD25	TCDM25	25 x 30

E' possibile inserire scritte con qualsiasi carattere (vedi pag. 158)
Il colore delle scritte può essere nero o grigio
It's possible to put any text types (see page 158)
The colour of the writings can be black or grey

Targhe a Parete

Targa **Canova**



Targa Caravaggio - *Caravaggio wall Plaque*

Articolo - *Item*

Misure - *Size*

TCR45

cm 45 x 30

Il prodotto è equipaggiato con perni sul retro per il montaggio
The product is equipped with screws on the back to be fixed

Am197

Applicazione della targa su lapide
Plaque application on a tombstone



Targhe a Parete

Targa **Caravaggio**

Modelli Depositati



Targhe a Parete

Il prodotto è equipaggiato con perni sul retro per il montaggio
The product is equipped with screws on the back to be fixed

Targa Raffaello - Raffaello wall Plaque

Articolo - Item

Misure - Size

TR42

cm 42 x 15,5



Am204

Applicazione della targa su lapide
Plaque application on a tombstone



Targhe a Parete

Targa **Raffaello**

Modelli Depositati



Am205



Am206



Am207



Am208



Am209



Am210

Targhe a Parete



Am211



Am212



Am213



Am214

Targa Raffaello solo Scritta

Raffaello wall plaque only with writings

Articolo - Item		Misure - Size
Bianco	Decorato	cm
TRD42	TRDM42	42 x 15,5

E' possibile inserire scritte con qualsiasi carattere (vedi pag. 158)
Il colore delle scritte può essere nero o grigio

It's possible to put any text types (see page 158)
The colour of the writings can be black or grey



Bianco - White



Decorato - Decorated

Marmorizzazioni disponibili a pag. 183
Available stone decorations on page 183

Targhe a Parete

Targa **Raffaello**

Modelli Depositati

Il prodotto è equipaggiato con perni sul retro per il montaggio
 The product is equipped with screws on the back to be fixed

Targa Tintoretto - *Tintoretto wall Plaque*

Articolo - *Item*

Misure - *Size*

TT45

cm 45 x 15



Am215

Applicazione della targa su lapide
 Plaque application on a tombstone



Targhe a Parete



Am216



Am217



Am218



Am219



Am220



Am221

Targhe a Parete

Targa **Tintoretto**

Modelli Depositati



Am222



Am223



Am224



Am225

Targa Tintoretto solo Scritta

Tintoretto wall plaque only with writings

Articolo - Item	Misure - Size
Bianco Decorato	cm
TTD45 TTD45	45 x 15

E' possibile inserire scritte con qualsiasi carattere (vedi pag. 158)

Il colore delle scritte può essere nero o grigio

It's possible to put any text types (see page 158)

The colour of the writings can be black or grey



Bianco - White



Decorato - Decorated

Marmorizzazioni disponibili a pag. 183
Available stone decorations on page 183

Targhe a Parete

Modelli Depositati

Targa **Tintoretto**

L'elegante linea di libri a parete prodotti da Polistampa è proposta nelle varianti: "Classic" con pareti lisce e "Cornice" con una cornice a rilievo che risalta la foto. Con il nuovo catalogo, oltre al restyling stilistico dei modelli preesistenti, vengono introdotti altri due modelli di libro: "Tiziano" e "Degas" che completano l'offerta per grandi formati.

The elegant wall line of books produced by Polistampa are proposed in the variants: "Classic" with smooth walls and "Frame" with a frame in relief that stands out on the photo. With the new catalogue, in addition to restyling stylistic models already in existence, introduces two additional models of the book line: "Tiziano" and "Degas" that complete the offer for large formats.

WALL BOOKS

LIBRI A PARETE



Libro Classic - Classic wall Book

Articolo - Item	Misure -Size
L16CLA	cm 16 x 23
L21CLA	cm 21 x 29
L24CLA	cm 24 x 32

Il prodotto è equipaggiato con perni sul retro per il montaggio
 The product is equipped with screws on the back to be fixed

Am226

Libro Classic solo Scritta

Classic wall Book only with writings

Articolo - Item	Misure -Size
Bianco	Decorato
LD16CLA	LDM16CLA
LD21CLA	LDM21CLA
LD24CLA	LDM24CLA

E' possibile inserire scritte con qualsiasi carattere (vedi pag. 158)

Il colore delle scritte può essere nero o grigio

It's possible to put any text types (see page 158)

The colour of the writings can be black or grey



Bianco - White



Decorato - Decorated

Marmorizzazioni disponibili a pag. 183
 Available stone decorations on page 183

Libri a Parete

Su richiesta, è possibile realizzare soluzioni personalizzate.
 On demand, we can realize personalized solutions.

Libro Classic



Am227



Am228



Am229



Am230



Am231



Am232



Am233



Am234



Am235



Am236



Am237



Am238



Am239



Am240



Am241



Am242



Am243



Am244

Il prodotto è equipaggiato con perni sul retro per il montaggio
 The product is equipped with screws on the back to be fixed

Libro Cornice - Frame wall Book

Articolo - Item	Misura Foto -Photo Size	Misure -Size
L16COR	cm 6 x 8	cm 16 x 23
L21COR	cm 7 x 10	cm 21 x 29
L24COR	cm 9 x 12	cm 24 x 32



Am245



Dettaglio in prospettiva della cornice in rilievo
 View of the frame in relief

Libri a Parete

Su richiesta, è possibile realizzare soluzioni personalizzate.
 On demand, we can realize personalized solutions.

Libro Cornice



Am246



Am247



Am248



Am249



Am250



Am251



Am252



Am253



Am254



Am255



Am256



Am257



Am258



Am259



Am260



Am261



Am262



Am263



Am264

Libro Tiziano - Tiziano wall Book

Articolo - Item	Misure -Size
L30TIZ	cm 30 x 36
L36TIZ	cm 36 x 50

Altri fondi disponibili a pag 143
Available Backgrounds on page 143

Il prodotto è equipaggiato con perni sul retro per il montaggio
The product is equipped with screws on the back to be fixed



Am265

Libro Degas - Degas wall Book

Articolo - Item	Misure -Size
L39DEG	cm 39 x 44

Altri fondi disponibili a pag 143
Available Backgrounds on page 143

Il prodotto è equipaggiato con perni sul retro per il montaggio
The product is equipped with screws on the back to be fixed

Libri a Parete

L'esclusiva linea di pergamene a parete prodotte da Polistampa è proposta nelle varianti: "Classic" con superficie liscia e "Cornice" con una cornice a rilievo che risalta la foto. Vengono inoltre introdotte tre nuove pergamene: "Monet", "Renoir" e "Césanne" che ampliano l'offerta di modelli e misure disponibili.

Anche le pergamene sono state tutte rivisitate nella grafica in linea con la nuova idea di sobrietà ed eleganza adottata dalla nostra Azienda.

The exclusive line of parchments wall produced by Polistampa are proposed in the variants: "Classic" with smooth surface and "Frame" with a frame in relief that stands out on the photo. Also introduced three new parchments: "Monet", "Renoir" and "Cézanne" that expand the range of models and sizes available.

The parchments were all re-visited in graphic design in accordance with the new idea of sobriety and elegance adopted by our company.

WALL PARCHMENTS

PERGAMENE A PARETE

Il prodotto è equipaggiato con perni sul retro per il montaggio
 The product is equipped with screws on the back to be fixed



Am266

Pergamena Classic
 Classic wall Parchment

Articolo - Item	Misure -Size
P5CLA	cm 5 x 10
P9CLA	cm 9 x 16
P10CLA	cm 10 x 18
P13CLA	cm 13 x 22
P15CLA	cm 15 x 28
P18CLA	cm 18 x 34
P20CLA	cm 20 x 41
P33CLA	cm 33 x 51

Pergamena Classic solo Scritta

Classic wall Parchment only with Writings

Articolo - Item	Misure -Size
Bianco	Decorato
PD5CLA	PDM5CLA
PD9CLA	PDM9CLA
PD10CLA	PDM10CLA
PD13CLA	PDM13CLA
PD15CLA	PDM15CLA
PD18CLA	PDM18CLA
PD20CLA	PDM20CLA



Bianco - White



Decorato - Decorated

E' possibile inserire scritte con qualsiasi carattere (vedi pag. 158)
 Il colore delle scritte può essere nero o grigio
 It's possible to put any text types (see page 158)
 The colour of the writings can be black or grey

Marmorizzazioni disponibili a pag. 183
 Available stone decorations on page 183

Pergamene a Parete

Su richiesta, è possibile realizzare soluzioni personalizzate.
 On demand, we can realize personalized solutions.

Pergamena **Classic**



Am267



Am268



Am269



Am270



Am271



Am272

Pergamene a Parete

Pergamena **Classic**



Am273



Am274



Am275



Am276



Am277



Am278

Pergamene a Parete

Pergamena **Classic**



Am279



Am280



Am281



Am282



Am283



Am284

Pergamene a Parete

Pergamena **Classic**

Il prodotto è equipaggiato con perni sul retro per il montaggio
 The product is equipped with screws on the back to be fixed

Pergamena Cornice - *Frame wall Parchment*

Articolo - Item	Misura Foto -Photo Size	Misure -Size
P10COR	cm 4 x 6	cm 10 x 18
P13COR	cm 5 x 7	cm 13 x 22
P15COR	cm 6 x 8	cm 15 x 28
P18COR	cm 8 x 10	cm 18 x 34



Am285



Dettaglio in prospettiva della cornice in rilievo
 View of the frame in relief

Pergamene a Parete

Su richiesta, è possibile realizzare soluzioni personalizzate.
 On demand, we can realize personalized solutions.

Pergamena **Cornice**



Am286



Am287



Am288



Am289



Am290



Am291

Pergamene a Parete

Pergamena **Cornice**



Am292



Am293



Am294



Am295



Am296



Am297

Pergamene a Parete

Pergamena **Cornice**



Am298

Il prodotto è equipaggiato con perni sul retro per il montaggio
The product is equipped with screws on the back to be fixed

Pergamena Monet
Monet wall Parchment

Articolo - Item	Misure -Size
P15MON	cm 15 x 24
P21MON	cm 21 x 31



Bianco - White



Decorato - Decorated

Marmorizzazioni disponibili a pag. 183
Available stone decorations on page 183

Pergamena Monet solo Scritta
Monet wall Parchment only with Writings

Articolo - Item	Misure -Size
Bianco Decorato	cm
PD15MON	PDM15MON 15 x 24
PD21MON	PDM21MON 21 x 31

E' possibile inserire scritte con qualsiasi carattere (vedi pag. 158)
Il colore delle scritte può essere nero o grigio
It's possible to put any text types (see page 158)
The colour of the writings can be black or grey

Pergamene a Parete

Pergamena **Monet**

Su richiesta, è possibile realizzare soluzioni personalizzate.
On demand, we can realize personalized solutions.



Am299



Am300



Am301



Am302



Am303



Am304

Pergamene a Parete

Pergamena **Monet**

Il prodotto è equipaggiato con perni sul retro per il montaggio
The product is equipped with screws on the back to be fixed

Pergamena Césanne - *Césanne wall Parchment*

Articolo - *Item*

P16CES

P20CES

Misure - *Size*

cm 16 x 31

cm 20 x 40



Am305

Pergamene a Parete

Pergamena **Césanne**

Su richiesta, è possibile realizzare soluzioni personalizzate.
On demand, we can realize personalized solutions.



Am306



Am307



Am308



Am309



Am310



Am311

Pergamene a Parete

Pergamena **Césanne**



Am312

Pergamena Renoir - Renoir wall Parchment

Articolo - Item	Misure -Size
P22REN	cm 22 x 31
P25REN	cm 25 x 37
P36REN	cm 36 x 51

Altri fondi disponibili a pag 143
Available Backgrounds on page 143

Il prodotto è equipaggiato con perni sul retro per il montaggio
The product is equipped with screws on the back to be fixed



Bianco - White



Decorato - Decorated

Marmorizzazioni disponibili a pag. 183
Available stone decorations on page 183

Pergamena Renoir solo Scritta

Renoir wall Parchment only with Writings

Articolo - Item	Misure -Size
Bianco	Decorato
PD22REN	PDM22REN
PD25REN	PDM25REN
PD36REN	PDM36REN

E' possibile inserire scritte con qualsiasi carattere (vedi pag. 158)
Il colore delle scritte può essere nero o grigio
It's possible to put any text types (see page 158)
The colour of the writings can be black or grey

Pergamene a Parete

Pergamena **Renoir**

Su richiesta, è possibile realizzare soluzioni personalizzate.
On demand, we can realize personalized solutions.

Utilizzando lo stesso materiale innovativo di 2 cm di spessore con cui Polistampa produce le sue esclusive lapidi, vengono realizzati pannelli di varie misure raffiguranti immagini di qualsiasi tipo. Le differenze con le fotoceramiche sono molte: maggiore spessore, rifinitura dei bordi, effetto semi-opaco più naturale. Il risultato è quello di avere un prodotto che si integra in modo più naturale con le pietre utilizzate, con la stessa garanzia di durata di una foto su ceramica.

Using the same innovative material 2 cm thick which Polistampa produces its exclusive tombstones, are made of panels of various sizes depicting images of any kind.

The differences with photoceramic are many: greater thickness, finishing of the sides, semi-opaque effect more natural. The result is to have a product that integrates into most natural way with the stones used, with the same guarantee of duration of a photo on ceramics.

PHOTOSTONE
Thickness 2 cm

FOTOMARMO
Spessore 2 cm



FotoMarmo - PhotoStone

Articolo - Item	Misura Foto - Photo Size	Misura Pezzo - Piece Size
PIS17	cm 13 x 9	cm 17 x 13
PIS19	cm 15 x 11	cm 19 x 15
PIS24	cm 20 x 14	cm 24 x 18
PIS30	cm 26 x 20	cm 30 x 24
PIS47	cm 43,5 x 28,5	cm 47,5 x 32,5
PIS65	cm 61 x 40,5	cm 65 x 44,5
PIS95	cm 91 x 61	cm 95 x 65

Gli articoli realizzati con il MarmoCeramico hanno spessore 2 cm
The thickness of this article is cm 2

E' possibile realizzare pannelli su misura fino a cm 170 x 95
It's possible to realize panels with the size requested

E' possibile realizzare formati diversi dal rettangolare per misure oltre 40 x 40
It's possible to realize panels with other shapes for size beyond 40 x 40

SPESSORE cm 2 - Thickness cm 2

Il prodotto è equipaggiato con perni sul retro per il montaggio
The product is equipped with screws on the back to be fixed

Decorazioni disponibili per i Bordi *Available Border decorations*



M8 Rilievo Grigio



M9 Rilievo Beige



M10 Rilievo Rosa

Pannelli con immagine

FotoMarmo

FotoMarmo - PhotoStone



FotoMarmo con Immagine Sacra - PhotoStone with Sacred Image

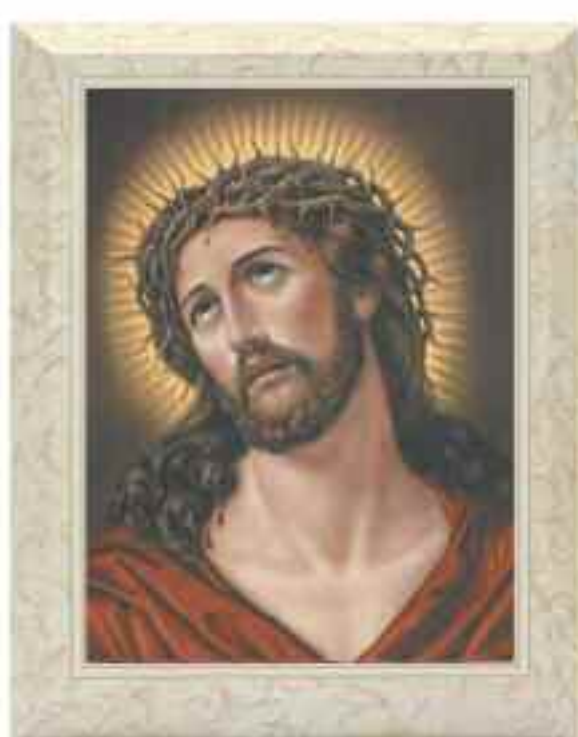

Pannelli con immagine



Supporto in Porcellana - Porcelain Support

Articolo - Item		Misure -Size
Bianco	Decorato	cm
SUP05	SUP05D	8
SUP06	SUP06D	14

Marmorizzazioni disponibili a pag. 183
Available stone decorations on page 183

Supporto in Porcellana largo - Large Porcelain Support

Articolo - Item		Misure -Size
Bianco	Decorato	cm
SUP07	SUP07D	13 x 8
SUP08	SUP08D	15 x 11
SUP09	SUP09D	20 x 16

Marmorizzazioni disponibili a pag. 183
Available stone decorations on page 183

Supporto in Inox - Inox Support

Articolo - Item	Misure -Size
SUP10	cm 13 x 7
SUP11	cm 15 x 13,5
SUP12	cm 20 x 17

Placche in porcellana di grandi dimensioni da applicare su loculi in marmo. Le fotolapidi danno la possibilità di sviluppare tutti gli elementi di una lapide su un fondo fotografico (paesaggi, composizioni floreali ecc.). Tale soluzione oltre ad essere di facile applicazione, rappresenta un nuovo modo di raccontare e ricordare i nostri cari.

Porcelain Plaques of large dimensions that can be applied on tombstone. The porcelain-tombstone give the opportunity to develop all those elements of a tombstone on a photographic collection (landscapes, floral compositions etc.). Such solution in addition to being easy to apply, represents a new way of telling and remember our loved ones.

PORCELAIN TOMBSTONES
Thickness 9 mm

FOTOLAPIDI PORCELLANA
Spessore 9 mm

Fotolapide in Porcellana - Porcelain PhotoTombstone

Articolo - Item

Misure -Size

FL40

cm 40 x 60

FL50

cm 50 x 70

Altri fondi disponibili a pag 143

Available Backgrounds on page 143

Scelta Accessori in porcellana abbinati a pag 160

Selection of coupled porcelain vases on page 160



Fotolapidi in Porcellana

Fotolapide

Su richiesta, è possibile realizzare soluzioni personalizzate.
On demand, we can realize personalized solutions.

Altri fondi disponibili a pag 143

Available Backgrounds on page 143

Scelta Accessori in porcellana abbinati a pag 160

Selection of coupled porcelain vases on page 160



Fotolapidi in Porcellana

Fotolapide

Gli articoli a terreno sono tra i prodotti che più hanno beneficiato della nuova tendenza stilistica adottata da Polistampa. Le nuove soluzioni decorative adottate rendono i nostri prodotti da appoggio unici per eleganza e modernità.

The ground articles are among the products that most benefited from new stylistic trend adopted by Polistampa. New decorative solutions adopted make our products a unique support for elegance and modernity.

GROUND PORCELAINS

PORCELLANE A TERRENO

Pergamena Cuore - *Heart Parchment*

Articolo - *Item*

Misure - *Size*
cm (L - H - P)

TER100

20 x 17 x 13

Misura della foto cm 12 x 11
Photo size cm 12 x 11



Am313



Vista del pezzo in prospettiva
Prospect view of the article



Am314

Porcellane a Terreno

Su richiesta, è possibile realizzare soluzioni personalizzate.
On demand, we can realize personalized solutions.

Pergamena **Cuore**



Am315



Am316



Am317



Am318



Am319



Am320



Am321



Am322

Pergamena Madonna - Mary Parchment

Articolo - Item

Misure - Size
cm (L - H - P)

TER300

24 x 21 x 12

Misura della foto cm 7 x 8
Photo size cm 7 x 8



Vista del pezzo in prospettiva
Prospect view of the article

Am323

Porcellane a Terreno

Pergamena **Madonna**

Su richiesta, è possibile realizzare soluzioni personalizzate.
On demand, we can realize personalized solutions.



Am324



Am325



Am326



Am327



Am328



Am329

Porcellane a Terreno

Pergamena **Madonna**



Am330

Libro Classic - Ground Classic Book

Articolo - Item	Misure -Size cm (L - H - P)
TER401	24 x 14,5 x 10
TER402	30 x 24 x 14



Vista del pezzo in prospettiva
Prospect view of the article

Libro Classic solo scritte

Ground Classic Book only with writings

Articolo - Item	Misure -Size cm
Bianco	Decorato
TER401D	TER401DM 24 x 14,5 x 10
TER402D	TER402DM 30 x 24 x 14

E' possibile inserire scritte con qualsiasi carattere (vedi pag. 158)
Il colore delle scritte può essere nero o grigio
It's possible to put any text types (see page 158)
The colour of the writings can be black or grey



Bianco - White



Decorato - Decorated

Marmorizzazioni disponibili a pag. 183
Available stone decorations on page 183

Porcellane a Terreno

Libro Classic

Su richiesta, è possibile realizzare soluzioni personalizzate.
On demand, we can realize personalized solutions.



Am331



Am332



Am333



Am334



Am335



Am336

Libro Cornice - Ground Frame Book

Articolo - Item

Misure -Size
cm (L - H - P)

TER400

24 x 14,5 x 10

Misura della foto cm 7 x 8
Photo size cm 7 x 8



Am337



Vista del pezzo in prospettiva
Prospect view of the article

Porcellane a Terreno

Libro **Cornice**

Su richiesta, è possibile realizzare soluzioni personalizzate.
On demand, we can realize personalized solutions.



Am338



Am339



Am340



Am341



Am342



Am343



Am344

Pergamena Classic - Ground Classic Parchment

Articolo - Item

Misure -Size
cm (L - H - P)

TER501

15 x 15 x 15



Vista del pezzo in prospettiva
Prospect view of the article

Pergamena Classic solo scritte

Ground Classic Parchment only with writings

Articolo - Item

Misure -Size

Bianco

Decorato

cm

TER501D

TER501DM

15 x 15 x 15

E' possibile inserire scritte con qualsiasi carattere (vedi pag. 158)

Il colore delle scritte può essere nero o grigio

It's possible to put any text types (see page 158)

The colour of the writings can be black or grey



Bianco - White



Decorato - Decorated

Marmorizzazioni disponibili a pag. 183
Available stone decorations on page 183

Porcellane a Terreno

Pergamena **Classic**

Su richiesta, è possibile realizzare soluzioni personalizzate.
On demand, we can realize personalized solutions.



Am345



Am346



Am347



Am348



Am349



Am350



Am351

Pergamena Cornice - *Ground Frame Parchment*

Articolo - *Item*

Misure - *Size*
cm (L - H - P)

TER500

15 x 15 x 15

Misura della foto cm 7 x 8
Photo size cm 7 x 8



Vista del pezzo in prospettiva
Prospect view of the article



Am352



Am353



Am354

Porcellane a Terreno

Pergamena **Cornice**

Su richiesta, è possibile realizzare soluzioni personalizzate.
On demand, we can realize personalized solutions.



Am355

Cuore Cornice - *Ground Frame Heart*

Articolo - *Item*

TER600

Misure - *Size*
cm (L - H - P)

18,5 x 10 x 16,5

Misura della foto cm 7 x 8
Photo size cm 7 x 8



Vista del pezzo in prospettiva
Prospect view of the article



Am356



Am357

Porcellane a Terreno

Su richiesta, è possibile realizzare soluzioni personalizzate.
On demand, we can realize personalized solutions.

Cuore **Cornice**



Am358



Am359



Am360



Am361



Am362



Am363

Porcellane a Terreno

Cuore **Cornice**

Valida alternativa alla ceramica, Diamante è un prodotto che, attraverso un processo di lavorazione del tutto innovativo, coniuga al meglio nitidezza d'immagine e inalterabilità nel tempo del cristallo.

Realizzata su cristallo puro, la stampa fotografica acquista grande profondità, valorizzata com'è dai giochi di luce creati dalle sfaccettature del cristallo.

La Polistampa amplia la propria offerta di cristalli sia per quanto riguarda le misure disponibili che per i formati (rettangolare, ottagonale, quadrato, ovale) con vari tipi di lavorazione dei bordi.

A valid alternative to ceramic, Diamond is a product that, through a machining process completely innovative, uniting image sharpness and incorruptibility in time of Crystal.

Built on pure crystal, printing photo buy great depth, valued as has subdued light created by facets of Crystal.

Polistampa extends its offer of crystals in sizes and formats adding (rectangular, octagonal, square, oval) with various types of machining of the edges.

DIAMANT
Crystal Articles

DIAMANTE

Articoli in Cristallo



Smusso trasparente - *Transparent blunting*

Rettangolare - *Rectangular Crystal*

Articolo - <i>Item</i>		Misure - <i>Size</i>
Colori	Bianco/Nero	cm
DR9	DR9BN	9 x 12
DR11	DR11BN	11 x 15
DR13	DR13BN	13 x 18
DR18	DR18BN	18 x 24
DR20	DR20BN	20 x 25
DR24	DR24BN	24 x 30
DR30	DR30BN	30 x 40
DR40		40 x 60
DR50		50 x 70

Per la colorazione Seppia aggiungere "SEPIA" al codice dei colori
For Sepia Colour add "SEPIA" to the colour Item

Le misure si riferiscono al pezzo finito
Size of the finished product

Il Diamante è equipaggiato con una piastra in metallo sul retro con alloggiamento delle viti per il fissaggio.
The Diamant is equipped on the back with a metal plaque with screws to fix it on the wall



Smusso Foto piena - *Blunting whole Photo*



Taglio netto Foto piena - *Net cut whole Photo*

Articoli in Cristallo

Diamante **Rettangolare**

A Richiesta è possibile avere supporti a parete spessorati fissi ed orientabili o supporti a terreno fissi (vedi pag. 129)
On demand we can supply different wall and ground support (see page 129)



Smusso trasparente - *Transparent blunting*

Ottagonale - *Octagonal Crystal*

Articolo - <i>Item</i>		Misure - <i>Size</i>
Colori	Bianco/Nero	cm
DOT12	DOT12BN	12 x 15
DOT14	DOT14BN	14 x 18
DOT16	DOT16BN	16 x 21

Per la colorazione Seppia aggiungere "SEPIA" al codice dei colori
For Sepia Colour add "SEPIA" to the colour Item

Le misure si riferiscono al pezzo finito
Size of the finished product

Il Diamante è equipaggiato con una piastra in metallo sul retro con alloggiamento delle viti per il fissaggio.
The Diamant is equipped on the back with a metal plaque with screws to fix it on the wall



Smusso Foto piena - *Blunting whole Photo*

Articoli in Cristallo

A Richiesta è possibile avere supporti a parete spessorati fissi ed orientabili o supporti a terreno fissi (vedi pag. 129)
On demand we can supply different wall and ground support (see page 129)

Diamante **Ottagonale**



Smusso trasparente - *Transparent blunting*

Quadrato - *Square Crystal*

Articolo - *Item*

Misure - *Size*

Colori	Bianco/Nero	cm
DQ13	DQ13BN	13 x 13
DQ18	DQ18BN	18 x 18
DQ24	DQ24BN	24 x 24

Per la colorazione Seppia aggiungere "SEPIA" al codice dei colori
For Sepia Colour add "SEPIA" to the colour Item

Le misure si riferiscono al pezzo finito
Size of the finished product

Il Diamante è equipaggiato con una piastra in metallo sul retro con alloggiamento delle viti per il fissaggio.
The Diamant is equipped on the back with a metal plaque with screws to fix it on the wall



Smusso Foto piena - *Blunting whole Photo*



Taglio netto Foto piena - *Net cut whole Photo*

Articoli in Cristallo

Diamante **Quadrato**

A Richiesta è possibile avere supporti a parete spessorati fissi ed orientabili o supporti a terreno fissi (vedi pag. 129)
On demand we can supply different wall and ground support (see page 129)



Taglio netto Foto piena - Net cut whole Photo

Ovale - Oval Crystal

Articolo - Item		Misure -Size
Colori	Bianco/Nero	cm
DOV9	DOV9BN	9 x 12
DOV11	DOV11BN	11 x 15
DOV13	DOV13BN	13 x 18
DOV18	DOV18BN	18 x 24

Per la colorazione Seppia aggiungere "SEPIA" al codice dei colori
 For Sepia Colour add "SEPIA" to the colour Item

Le misure si riferiscono al pezzo finito
 Size of the finished product

Il Diamante è equipaggiato con una piastra in metallo sul retro con alloggiamento delle viti per il fissaggio.
 The Diamant is equipped on the back with a metal plaque with screws to fix it on the wall

Articoli in Cristallo

A Richiesta è possibile avere supporti a parete spessorati fissi ed orientabili o supporti a terreno fissi (vedi pag. 129)
 On demand we can supply different wall and ground support (see page 129)

Diamante **Ovale**

Fotolapide in Cristallo - Crystal Tombstone

Articolo - Item

Misure -Size

DR40

cm 40 x 60

DR50

cm 50 x 70

Le misure si riferiscono al pezzo finito
Size of the finished product

Il Diamante è equipaggiato con una piastra in metallo sul retro con alloggiamento delle viti per il fissaggio
The Diamante is equipped on the back with a metal plaque with screws to fix it on the wall

Altri fondi disponibili a pag 143
Available Backgrounds on page 143



Articoli in Cristallo

Fotolapide in Cristallo

Piastra inox con viti standard per tutti i Diamanti

Standard metal plaque with screws for all Crystals

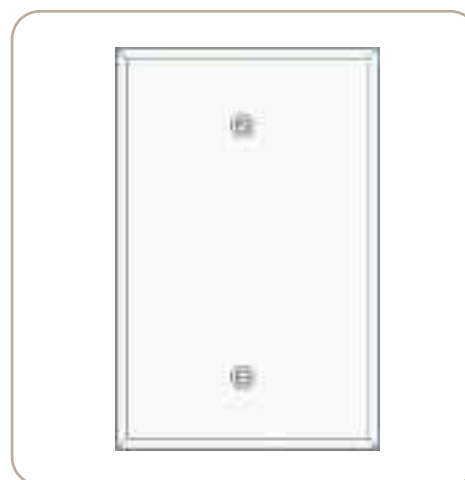

Supporti a parete - Wall Support

Articolo - Item	Descrizione - Description
SUP01	Supporto con snodo fisso - Fixed support
SUP02	Supporto con snodo orientabile - Adjustable support

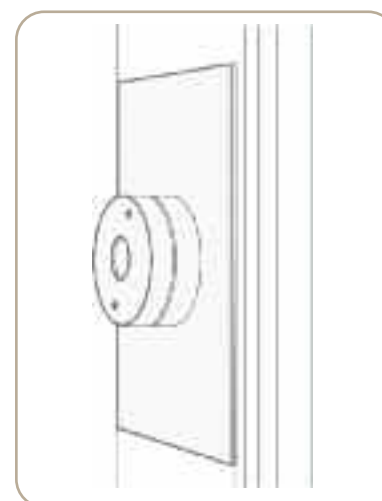

FISSO

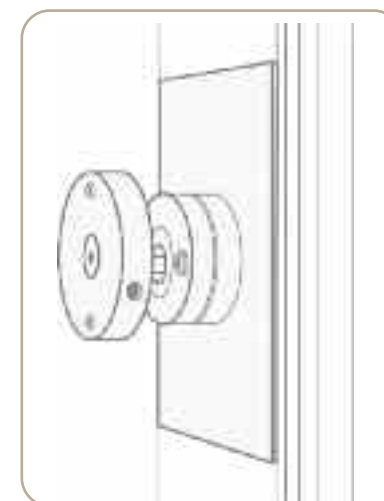

ORIENTABILE

Supporti a terreno - Ground Support

Articolo - Item	Descrizione - Description
SUP03	Supporto Braccio fisso (fino a cm 13 x 18) - Fixed arm support (till cm 13 x 18)
SUP04	Supporto Braccio fisso (oltre cm 13 x 18) - Fixed arm support (beyond cm 13 x 18)



Accessori

La scelta di esclusivi soggetti religiosi e di elementi della natura in qualche modo sacrali ed evocativi, fa dei ricordini di nostra produzione il modo migliore per ricordare chi ci è stato vicino.

In particolare sui ricordini plastificati, come sulle fotoceramiche, sono state adottate le soluzioni grafiche "Ambiente" che impreziosiscono la fotografia.

The choice of exclusive religious subjects and elements of nature somehow sacral and evocative, are for our remembrancers the best way to remember who was close.

On the plastified remembrancers, like on the photoceramic, new solution "Ambiente" is adopted so that it embellish the photograph.

PRINTS AND REMEMBRANCERS

Paper articles

STAMPE E RICORDINI

Articoli Cartacei



Ricordini Plastificati - *Plastified Remembrancers*

Articolo - <i>Item</i>	Misure - <i>Size</i>
RP6	cm 6 x 9
RP7	cm 7 x 10
RP9	cm 9 x 13
RP10	cm 10 x 15

Stampe Fotografiche - *Photographic Prints*

Articolo - <i>Item</i>	Misure - <i>Size</i>
F10	Stampa fino a cm 10 x 15
F11	Stampa cm 11 x 15
F13	Stampa cm 13 x 18
F18	Stampa cm 18 x 24
F24	Stampa cm 24 x 30
F30	Stampa cm 30 x 40
F40	Stampa cm 40 x 60
F50	Stampa cm 50 x 70

Particolari ambientazioni disponibili per i ricordini plastificati
Particular available decorations for the plastified remembrancers



FRONTE Am364



FRONTE Am365



FRONTE Am366



FRONTE Am367



FRONTE Am368



FRONTE Am369



FRONTE Am370



FRONTE Am371

Articoli Cartacei

Ricordini **Plastificati Ambiente**

Scelta Immagini Sacre per i modelli Am367 e Am371 a pag. 150
Available Sacred Images for models Am367 and Am371 on page 150

Particolari ambientazioni disponibili per il **retro** dei ricordini plastificati
 Particular available decorations for the **back** of the plastified remembrancers

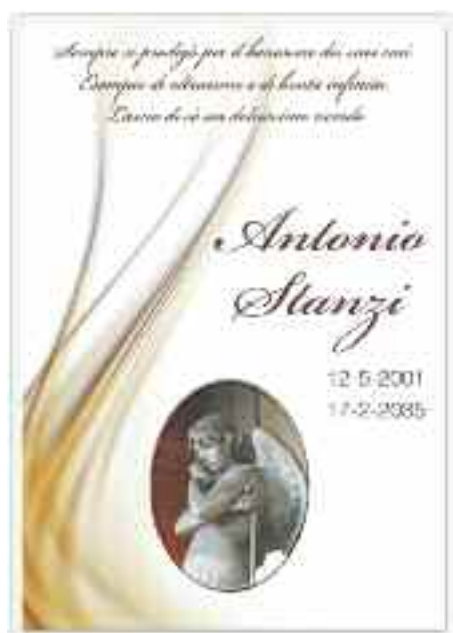

RETRO Am372



RETRO Am373



RETRO Am374



RETRO Am375



RETRO Am376

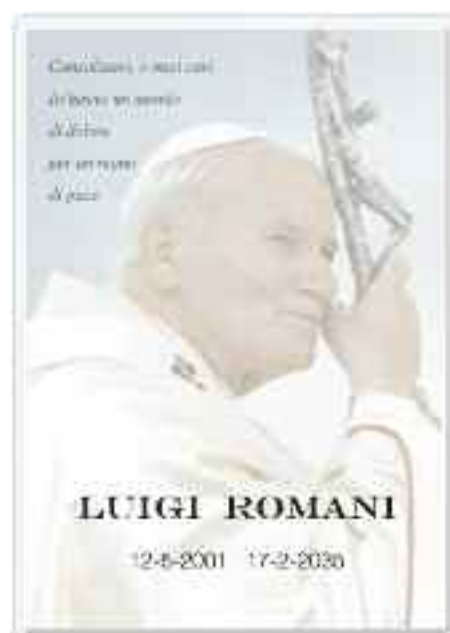

RETRO Am377



RETRO Am378



RETRO Am379

Articoli Cartacei

Scelta Immagini Sacre per i modelli Am372 e Am376 a pag. 150
 Available Sacred Images for models Am372 and Am376 on page 150

Ricordini **Plastificati Ambiente**



Immagini Ricordo - Remembrancers with Image

Articolo - Item

Misure -Size

IR

cm 8,5 x 13



IR1412

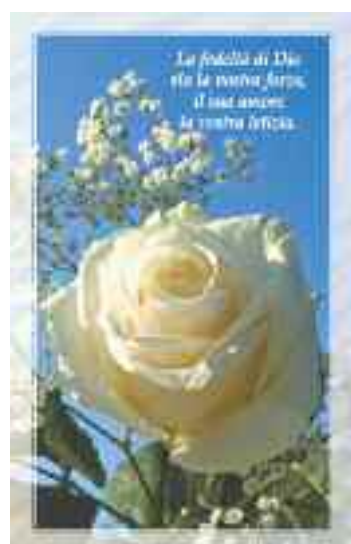

IR1388



IR1256



IR1439



IR1242



IR1316



IR1188

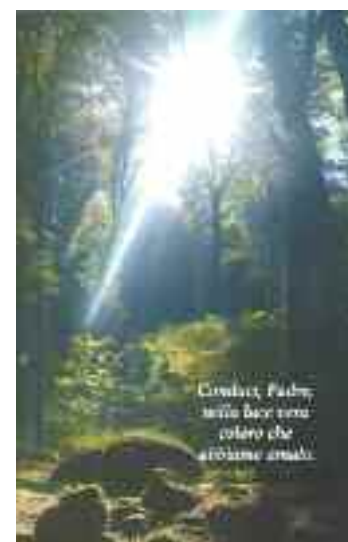

IR1167

Articoli Cartacei

Immagini **Ricordo**

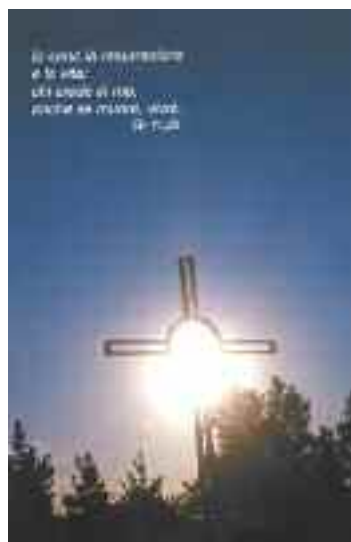

IR134



IR1252



IR1218



IR1152



IR261



IR796



IR329

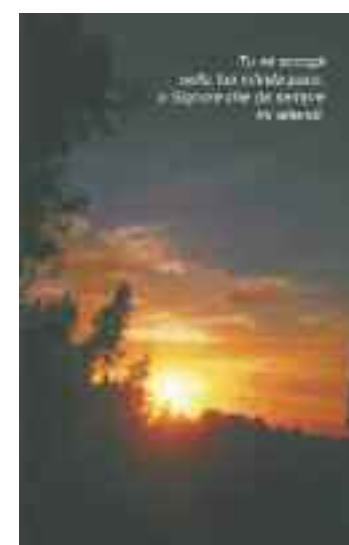

IR80

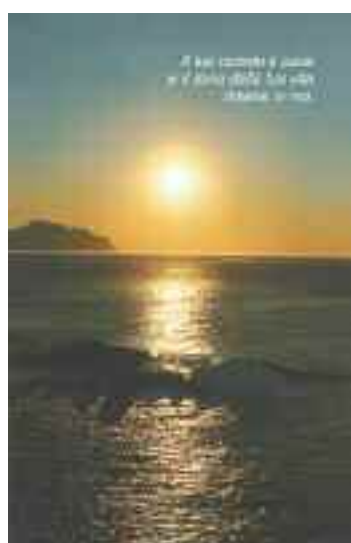

IR60

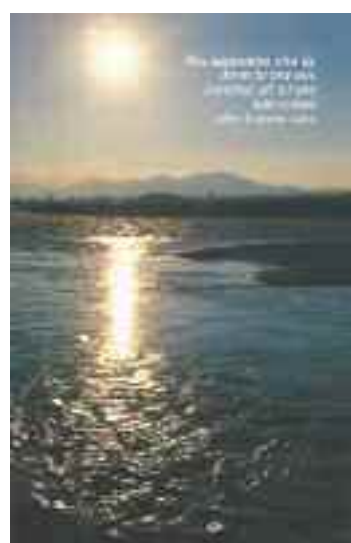

IR287



IR864



IR780

Articoli Cartacei

Immagini **Ricordo**



Ricordini Finestrella - Window Remembrancers

Articolo - Item	Misure - Size
RF105 (dall' Art. 100 al 105)	cm 7 x 11,5
RF110 (dall' Art. 106 al 110)	cm 7 x 11,5
RF115 (dall' Art. 111 al 114)	cm 7 x 11,5

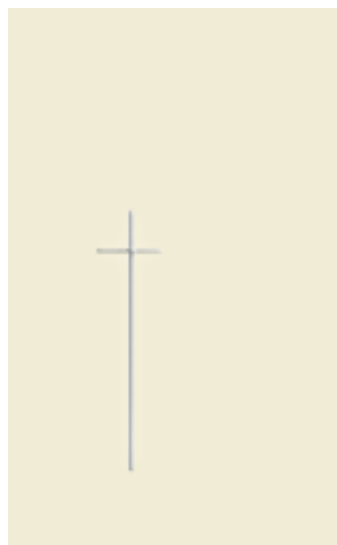

RF100



RF101

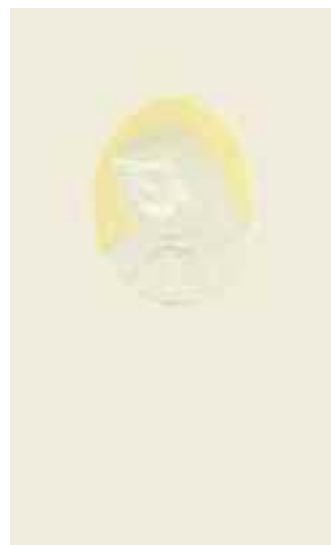

RF102



RF103



RF104



RF105



RF106



RF107



RF108



RF109



RF110

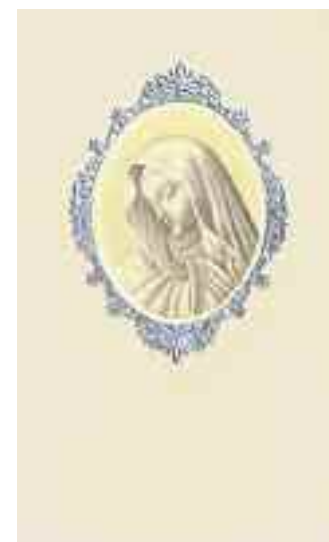

RF111



RF112



RF113



RF114

Il ventaglio di offerte di fondi e abiti è stato aggiornato ed ampliato per offrire una vastissima scelta a tutto vantaggio dell'immagine da inserire. Tra le novità introdotte; un gamma di proposte di ambienti (paesaggi) ad alta risoluzione da poter scegliere per la realizzazione di ceramiche di grande formato come libri, targhe, pergamene e fotolapidi.

The portfolio of funds and clothes has been updated and expanded to offer a huge choice in favour of the image to insert. Among the novelties introduced; a wide range of proposals of environments (landscapes) high-resolution to choose from for the realization of large-format ceramics as books, plaques, parchments and photo-tombstones.

BACKGROUNDS AND CLOTHES
Graphic Solutions

FONDI E ABITI
Soluzioni Grafiche



101



102



103



104



105



106



107



108



109



110



111



112

Soluzioni Grafiche



113



114



115



116



117



118



119



120



121



122



123



124

Soluzioni Grafiche

Fondi

Fondi per fotoceramiche *Photoceramic backgrounds*



125



126



127



128



129



130



131



132



133



134



135



136

Soluzioni Grafiche



137



138



139



140



141



142



143



144



145



146



147



148



200



201



202



203



204



205



206



207



208



209



210



211

Soluzioni Grafiche



212



213



214

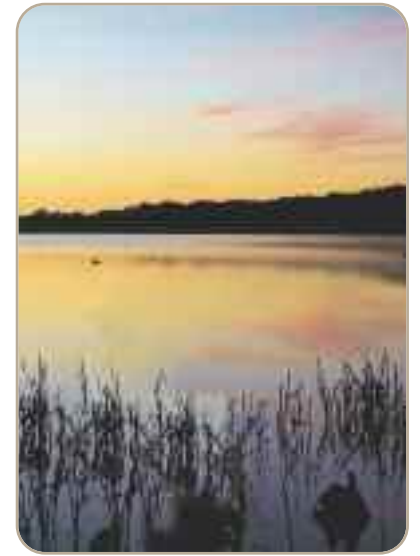

215



216



217



218



219



220



221



222



223



224



225



226



227



228



229



230



231



232



233



234



D50



D51



D52



D53



D54



D55



D56



D57



D58



D59



D60



D61

Soluzioni Grafiche

Abiti **Donna**

Scelta abiti donna Available woman clothes



D62



D63



D64



D65



D66



D67



D68



D69



D70



D71



D72



D73

Soluzioni Grafiche



U80



U81



U82



U83



U84



U85



U86



U87



U88



U89



U90



U91

Soluzioni Grafiche

Abiti **Uomo**

Scelta abiti uomo Available man clothes



U92



U93



U94



U95



U96



U97



U98



U99



U100



U101



U102



U103

Soluzioni Grafiche

Di seguito una selezione di immagini Sacre e Floreali ad altissima risoluzione da poter scegliere ed inserire nella composizione dei nostri prodotti.

This is a selection of sacred images and Floral ultra-high resolution to choose from and insert in compositions of our products.

IMAGES

IMMAGINI



IM 01



IM 02



IM 03



IM 04



IM 05



IM 06

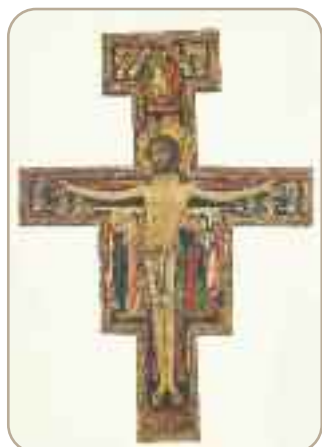

IM 07



IM 08



IM 09



IM 10



IM 11



IM 12



IM 13



IM 14



IM 15



IM 16



IM 17



IM 18



IM 19



IM 20



IM 21



IM 22



IM 23



IM 24



IM 25



IM 26



IM 27



IM 28



IM 29



IM 30



IM 34



IM 35



IM 46



IM 47



IM 48



IM 49



IM 50



IM 51



IM 52



IM 53



IM 54



IM 55



IM 31



IM 32



IM 33



IM 36



IM 37



IM 38



IM 39



IM 40



IM 41



IM 42



IM 43



IM 44



IM 45



IM 56



IM 57



IM 58



IM 59



IM 60



IM 61



IM 62



IM 63



IM 64



IM 65



IM 66



IM 67



IM 68



IM 69



IM 70



IM 71



IM 72



IM 73



IM 74



IM 75

Soluzioni Grafiche

Immagini **Floreali**

Scelta Immagini Floreali Available Floreal Images



IM 76



IM 77



IM 78



IM 79



IM 80



IM 81



IM 82



IM 83



IM 84



IM 85



IM 86



IM 87



IM 88



IM 89



IM 90



IM 91



IM 92



IM 93



IM 94



IM 95



IM 96



IM 97



IM 98



IM 99

Soluzioni Grafiche

N. 1 Consolatevi o miei cari, io lascio un mondo di dolore per un regno di pace	N. 2 Non piangete, io continuerò ad amarvi al di là della vita. L'amore è l'anima e l'anima non muore.	N. 3 "Non si perdono mai coloro che amiamo, perchè possiamo amarli in Colui che non si può perdere"	N. 4 L'amore che hai dato non è morto con te: vive nel nostro cuore, nel nostro ricordo. La fede mantiene uniti quelli che la morte separa.	N. 5 La dolce tua pace si posi sul nostro dolore.	N. 6 Io sono la resurrezione e la vita. Chi crede in me, quand'anche esso fosse morto, vivrà e chi vive e crede in me non morirà in eterno.
N. 7 Sempre si prodigò per il benessere dei suoi cari. Esempio di altruismo e di bontà infinita. Lascia di sé un dolcissimo ricordo.	N. 8 L'alba di ogni giorno ti porti l'amore di mamma e papà.	N. 9 I morti non sono degli assenti, sono degli invisibili che tengono i loro occhi pieni di luce nei nostri pieni di lacrime.	N. 10 La tua morte inattesa lascia un gran vuoto fra tutti coloro che ti amarono. Nel loro animo sarà sempre vivo il tuo ricordo.	N. 11 Mamma, come sulla terra ci guidasti nei nostri primi passi, ora dal cielo guidaci nel retto sentiero della vita.	N. 12 L'assenza non è assenza, abbiate fede, colui che non vedete è con voi.
N. 13 "Vissi ammirando, odorando la terra e il cielo. Continuo l'eterno cammino della vita immortale".	N. 14 "So che in fondo alla strada il Signore mi aspetta".	N. 15 Non piangete la mia assenza, sono beata in Dio e prego per voi. Io vi amerò dal cielo come vi ho amato sulla terra.	N. 16 Non piangete la mia assenza, sono beato in Dio e prego per voi. Io vi amerò dal cielo come vi ho amato sulla terra.	N. 17 Con rimpianto e tenerezza infinita ti ricordiamo e preghiamo per te.	N. 18 ... Resterai sempre nel cuore di quanti ti vollero bene ...
N. 19 E' con grande dolore che ti abbiamo perduta, ma ci conforta la certezza di rivederti in cielo.	N. 20 E' con grande dolore che ti abbiamo perduto, ma ci conforta la certezza di rivederti in cielo.	N. 21 Chi vive nel cuore di chi resta non muore.	N. 22 E' andato in cielo a raggiungere quelli che l'amarono e ad attendere quelli che l'amano.	N. 23 Madre affettuosa ed onesta le sue doti furono di esempio a quanti la conobbero.	N. 24 Nessuno ha amore più grande di colui che sacrifica la vita per gli altri.
N. 25 Serenamente si addormentò nel Signore dopo una vita interamente dedicata alla famiglia e al lavoro. Moglie e madre esemplare lascia al marito e ai figli un'eredità di fede e di amore.	N. 26 La sua cara memoria vivrà per sempre nell'animo di quanti la conobbero e le vollero bene.	N. 27 Nella fede di Cristo trovano rassegnazione e speranza tutti quelli che mi onorarono.	N. 28 Il destino ti ha tolto troppo presto all'affetto della famiglia ma non ti toglierà mai dalla nostra memoria e dal nostro cuore.	N. 29 Voi che mi avete tanto amato non guardate la vita che lascio ma quella che comincio.	N. 30 La Tua pace si sposò nel cuore di quanti mi hanno amato e ora mi piangono.

N. 31 L'eterno Riposo dona a Lui o Signore e splenda ad esso la luce perpetua. Riposi in pace Così sia.	N. 32 "Non l'abbiamo perduta. Essa dimora prima di noi nella luce di Dio".	N. 33 Iddio conceda a te nel Cielo la pace dei giusti.	N. 34 L'immensità stessa di Dio viva nel tuo cuore, l'immensità stessa di Dio in te si raccolga.	N. 35 Resta Signore con me, perché oda la Tua voce e Ti segua ...	N. 36 Solo uno sguardo verso il cielo può addolcire il nostro dolore.
N. 37 Consolatevi con me voi tutti che mi eravate tanto cari. Io lascio un mondo di dolori per un Regno di Pace. (S. Caterina da Siena)	N. 38 REQUIEM Godi in Dio anima cara la pace dei giusti e conforta su questa terra chi tanto ti amò.	N. 39 Sempre vivo sei nei nostri cuori come sempre presente sei nella nostra casa desolata. Il Signore che ti colse improvvisamente doni l'eterno riposo alla tua anima benedetta.	N. 40 Non lasciatevi abbattere dal dolore, miei cari, mirate la vita che ho incominciato non quella che ho finito.	N. 41 Tu mi accogli nella tua infinita pace, o Signore che da sempre mi attendi.	N. 42 Visse per l'amore della famiglia. Riposa nella serenità del Giusto. Rivive nella luce di Dio.
N. 43 Gesù Bambino sia la stella che ti guidi lungo il deserto della vita presente.	N. 44 A tutti coloro che lo conobbero e l'amarono parché rimanga vivo il suo ricordo. (Una prece)	N. 45 Resta Signore con me, perché oda la Tua voce e Ti segua ...	N. 46 Onesto ed operoso lascia sulla terra le tracce luminose delle sue elette virtù.	N. 47 La fede mantiene uniti quelli che la morte separa.	N. 48 La morte ci ha separati, ma io continuerò a guidarvi dall'alto del cielo con l'aiuto del Signore.
N. 49 Visse per l'amore della famiglia. Riposa nella serenità del Giusto. Rivive nella luce di Dio.	N. 50 Tu che tanto ci amasti in vita veglia su di noi e guidaci perché possiamo sempre percorrere come te la giusta via della rettitudine e della bontà.	N. 51 "... Beati i puri di cuore perché vedranno Iddio ..."	N. 52 Che l'alba di ogni dì ti porti il sorriso di mamma e papà. Una prece	N. 53 Io vi amerò al di là della vita. L'amore è l'anima e l'anima non muore. Una prece	N. 54 "Consolatevi con me, voi tutti che mi eravate tanto cari. Io lascio un mondo di dolore per un regno di pace".
N. 55 Io sono la resurrezione e la vita, chi crede in me anche se morto vivrà e chi vive e crede in me non morrà in eterno.	N. 56 Riposa nella pace dei giusti, rivive nella luce di Dio.	N. 57 Tu mi accogli nella tua infinita pace, o Signore che da sempre mi attendi.	N. 58 Ricordatemi così con un sorriso, con una preghiera.	N. 59 Nessuno ha amore più grande di colui che sacrifica la vita per gli altri.	N. 60 Non piangete, sarò l'Angelo invisibile della famiglia. Dio non saprà negarmi niente quando io pregherò per voi.

<p>1) Helvetica A) ABCDEFGJHILMNOPQRSTUVWXYZ B) abcdefghilmnopqrstuvwxyz 1234567890</p>	<p>7) Flemish Script Bt A) ABCDEFGJHILMNOPQRSTUVWXYZ B) abcdefghilmnopqrstuvwxyz 1234567890</p>
<p>2) Garamond A) ABCDEFGJHILMNOPQRSTUVWXYZ B) abcdefghilmnopqrstuvwxyz 1234567890</p>	<p>8) Baskerville Old Face A) ABCDEFGJHILMNOPQRSTUVWXYZ B) abcdefghilmnopqrstuvwxyz 1234567890</p>
<p>3) Bell MT A) ABCDEFGJHILMNOPQRSTUVWXYZ B) abcdefghilmnopqrstuvwxyz 1234567890</p>	<p>9) <i>Huenstler Script</i> A) <i>A.B.C.D.E.F.G.H.I.L.M.N.O.P.Q.R.S.T.U.V.W.X.Y.Z</i> B) <i>abcdefghijklmnopqrstuvwxyz</i> <i>1234567890</i></p>
<p>4) <i>Bickham Script Pro</i> A) <i>A.B.C.D.E.F.G.H.I.L.M.N.O.P.Q.R.S.T.U.V.W.X.Y.Z</i> B) <i>abcdefghijklmnopqrstuvwxyz</i> <i>1234567890</i></p>	<p>10) <i>Lucida Calligraphy</i> A) <i>ABCDEFGHIJKLMNOPQRSTUVWXYZ</i> B) <i>abcdefghijklmnopqrstuvwxyz</i> 1234567890</p>
<p>5) Bookman Old Style A) ABCDEFGJHILMNOPQRSTUVWXYZ B) abcdefghilmnopqrstuvwxyz 1234567890</p>	<p>11) <i>Lucida Handwriting</i> A) <i>ABCDEFGHIJKLMNOPQRSTUVWXYZ</i> B) <i>abcdefghijklmnopqrstuvwxyz</i> 1234567890</p>
<p>6) Century Gothic A) ABCDEFGJHILMNOPQRSTUVWXYZ B) abcdefghilmnopqrstuvwxyz 1234567890</p>	<p>12) <i>Monotype Corsiva</i> A) <i>ABCDEFGHIJKLMNOPQRSTUVWXYZ</i> B) <i>abcdefghijklmnopqrstuvwxyz</i> 1234567890</p>

<p>13) Perpetua A) ABCDEFGJHILMNOPQRSTUVWXYZ B) abcdefgjhilmnopqrstuvwxyz 1234567890</p>	<p>19) Lainie Day A) ABCDEFGJHILMNOPQRSTUVWXYZ B) abcdefgjhilmnopqrstuvwxyz 1234567890</p>
<p>14) Piranesi Italic BT A) ABCDEFGJHILMNOPQRSTUVWXYZ B) abcdefgjhilmnopqrstuvwxyz 1234567890</p>	<p>20) Nadianne A) ABCDEFGJHILMNOPQRSTUVWXYZ B) abcdefgjhilmnopqrstuvwxyz 1234567890</p>
<p>15) Saffron Too A) ABCDEFGJHILMNOPQRSTUVWXYZ B) abcdefgjhilmnopqrstuvwxyz 1234567890</p>	<p>21) Old Script A) ABCDEFGJHILMNOPQRSTUVWXYZ B) abcdefgjhilmnopqrstuvwxyz 1234567890</p>
<p>16) Snell Bt A) ABCDEFGJHILMNOPQRSTUVWXYZ B) abcdefgjhilmnopqrstuvwxyz 1234567890</p>	<p>22) Sandy Text A) ABCDEFGJHILMNOPQRSTUVWXYZ B) abcdefgjhilmnopqrstuvwxyz 1234567890</p>
<p>17) Times A) ABCDEFGJHILMNOPQRSTUVWXYZ B) abcdefgjhilmnopqrstuvwxyz 1234567890</p>	<p>23) University Roman A) ABCDEFGJHILMNOPQRSTUVWXYZ B) abcdefgjhilmnopqrstuvwxyz 1234567890</p>
<p>18) Times New Roman A) ABCDEFGJHILMNOPQRSTUVWXYZ B) abcdefgjhilmnopqrstuvwxyz 1234567890</p>	<p>24) Vivaldi A) ABCDEFGJHILMNOPQRSTUVWXYZ B) abcdefgjhilmnopqrstuvwxyz 1234567890</p>

PORCELAIN ACCESSORIES

ACCESSORI IN PORCELLANA

Uno stile inconfondibile. Per la purezza dei materiali utilizzati, per il design, per la cura dei particolari e, soprattutto, per la durata nel tempo. Una dimostrazione di forza ed efficienza della nostra Azienda stà nell'impegno a spedire la merce in **24 ore** dall'acquisizione dell'ordine.

Oltre ad una rivisitazione delle decorazioni sui modelli preesistenti, Polistampa propone due nuove linee di accessori:

Linea Dune, uno stile moderno creato dal designer Luca Cimarra che rompe gli schemi delle linee tradizionali

Linea Flora, la delicatezza di una linea sobria abbinata all'eleganza di decorazioni fotografiche

*Unmistakable style. For the purity of materials used, for the design, care of details and, especially, for durability. A demonstration of strength and efficiency of our company lies in the commitment to send the goods within **24 hours** after acquisition of the order.*

Besides a revisiting of the decorations on pre-existing templates, Polistampa offers two new lines of accessories:

***Line Dune**, a modern style created by designer Luca Cimarra that breaks the traditional line*

***Line Flora**, the delicacy of a sober combined with the elegance of photographic decoration*



Linea Dune



Vaso h 21 Terreno DUN20T
Parete DUN20P

Vaso h 28,5 Terreno DUN30T

Vasca h 18 Terreno DUN18T
Parete DUN18P

Lampada Terreno DUN5T
Parete DUN5P

Accessori abbinati - *Coupled accessories*

Croce
Cross

Art. - Item	Misura - Size
C15	cm 15 x 9
C20	cm 20 x 11



Cornice Ovale
Oval Frame

Art. - Item	Misura - Size
CO8	cm 8 x 10
CO9	cm 9 x 12
CO11	cm 11 x 15
CO13	cm 13 x 18



Cornice Rettangolare
Rectangular Frame

Art. - Item	Misura - Size
CR9	cm 9 x 12
CR10	cm 10 x 15
CR11	cm 11 x 15
CR13	cm 13 x 18



Linea Dune

Carrara

Decorato - Decorated

Si aggiunge al codice dell'articolo bianco il codice relativo alla decorazione scelta.

Add to the white article item the code of the decoration chosen



Vaso h 21 Terreno DUN20T M2
Parete DUN20P M2

Vaso h 28,5 Terreno DUN30T M2

Vasca h 18 Terreno DUN18T M2
Parete DUN18P M2

Lampada Terreno DUN5T M2
Parete DUN5P M2

Accessori abbinati - Coupled accessories

Croce
Cross

Art. - Item	Misura - Size
C15 M2X	cm 15 x 9
C20 M2X	cm 20 x 11



Cornice Ovale
Oval Frame

Art. - Item	Misura - Size
CO8 M2X	cm 8 x 10
CO9 M2X	cm 9 x 12
CO11 M2X	cm 11 x 15
CO13 M2X	cm 13 x 18



Cornice Rettangolare
Rectangular Frame

Art. - Item	Misura - Size
CR9 M2X	cm 9 x 12
CR10 M2X	cm 10 x 15
CR11 M2X	cm 11 x 15
CR13 M2X	cm 13 x 18



M1 Travertino	M2 Carrara	M3 Verde Alpi	M4 Botticino	M5 Nero Africa	M6 Rosa Portogallo	M7 Rosa Beta	M11 Statuario	M12 Rosa Porrino	M13 Turkey
-------------------------	----------------------	-------------------------	------------------------	--------------------------	------------------------------	------------------------	-------------------------	----------------------------	----------------------



Scelta completa delle decorazioni disponibili a pag. 183
Complete decorations choice on page 183

Linea Flora



Vaso h 27 Terreno FLO30T

Vasca h 19 Terreno FLO18T
Parete FLO18P

Lampada Terreno FLO5T
Parete FLO5P

Vaso h 21 Terreno FLO20T
Parete FLO20P

Accessori abbinati - Coupled accessories

Croce
Cross

Art. - Item	Misura - Size
C15	cm 15 x 9
C20	cm 20 x 11



Cornice Ovale
Oval Frame

Art. - Item	Misura - Size
CO8	cm 8 x 10
CO9	cm 9 x 12
CO11	cm 11 x 15
CO13	cm 13 x 18



Cornice Rettangolare
Rectangular Frame

Art. - Item	Misura - Size
CR9	cm 9 x 12
CR10	cm 10 x 15
CR11	cm 11 x 15
CR13	cm 13 x 18



Linea Flora

Carrara parziale



Vaso h 27
Terreno FLO30T M2

Vasca h 19
Terreno FLO18T M2
Parete FLO18P M2

Lampada
Terreno FLO5T M2
Parete FLO5P M2

Vaso h 21
Terreno FLO20T M2
Parete FLO20P M2

Decoro Parziale - Partial Decoration

Si aggiunge al codice dell'articolo bianco il codice relativo alla decorazione scelta.

Add to the white article item the code of the decoration chosen

Accessori abbinati - Coupled accessories



Croce
C15
C20

Ovale
CO8
CO9
CO11
CO13

Rettangolare
CR9
CR10
CR11
CR13

Linea Flora

Carrara integrale



Vaso h 27
Terreno FLO30T M2X

Vasca h 19
Terreno FLO18T M2X
Parete FLO18P M2X

Lampada
Terreno FLO5T M2X
Parete FLO5P M2X

Vaso h 21
Terreno FLO20T M2X
Parete FLO20P M2X

Decoro Integrale - Full Decoration

Si aggiunge al codice dell'articolo bianco il codice relativo alla decorazione scelta più la lettera X

Add to the white article item the code of the decoration chosen plus the letter X

Accessori abbinati - Coupled accessories



Croce
C15 M2X
C20 M2X

Ovale
CO8 M2X
CO9 M2X
CO11 M2X
CO13 M2X

Rettangolare
CR9 M2X
CR10 M2X
CR11 M2X
CR13 M2X

- | | | | | | | | | | |
|-------------------------|----------------------|-------------------------|------------------------|--------------------------|------------------------------|------------------------|-------------------------|----------------------------|----------------------|
| M1
Travertino | M2
Carrara | M3
Verde Alpi | M4
Botticino | M5
Nero Africa | M6
Rosa Portogallo | M7
Rosa Beta | M11
Statuario | M12
Rosa Porrino | M13
Turkey |
|-------------------------|----------------------|-------------------------|------------------------|--------------------------|------------------------------|------------------------|-------------------------|----------------------------|----------------------|



Scelta completa delle decorazioni disponibili a pag. 183
Complete decorations choice on page 183



Bianco con Immagine - *White with Image*

Specificare il numero dell' immagine scelta.
Indicate the number of the chosen image

Es. FLO20T IM56

Le seguenti decorazioni floreali sono applicabili a tutti i modelli della linea Flora
It is possible to apply the following floreal decorations to all the Flora models

Vaso h 27
Terreno FLO30T IM

Vaso h 21
Terreno FLO20T IM
Parete FLO20P IM

Vasca h 19
Terreno FLO18T IM
Parete FLO18P IM

Lampada
Terreno FLO5T IM
Parete FLO5P IM



Linea Flora

Decorato con Immagine

Decorato con Immagine - *Decorated with Image*

Specificare il numero dell' immagine scelta ed il codice della decorazione scelta.

Indicate the number of the chosen image and the code of the chosen decoration.

Es. FLO20T IMX10 M2

Vaso h 27
Terreno FLO30T IMX

Vaso h 21
Terreno FLO20T IMX
Parete FLO20P IMX

Vasca h 19
Terreno FLO18T IMX
Parete FLO18P IMX

Lampada
Terreno FLO5T IMX
Parete FLO5P IMX

Linea Park



Vaso h 21 Terreno PAR20T
Parete PAR20P

Vaso h 27 Terreno PAR30T

Vasca h 19 Terreno PAR18T
Parete PAR18P

Lampada Terreno PAR5T
Parete PAR5P

Accessori abbinati - Coupled accessories

Croce
Cross

Art. - Item	Misura - Size
C15	cm 15 x 9
C20	cm 20 x 11



Cornice Ovale
Oval Frame

Art. - Item	Misura - Size
CO8	cm 8 x 10
CO9	cm 9 x 12
CO11	cm 11 x 15
CO13	cm 13 x 18



Cornice Rettangolare
Rectangular Frame

Art. - Item	Misura - Size
CR9	cm 9 x 12
CR10	cm 10 x 15
CR11	cm 11 x 15
CR13	cm 13 x 18





Linea Park

Carrara parziale

Vaso h 21
Terreno PAR20T M2
Parete PAR20P M2

Vaso h 27
Terreno PAR30T M2

Vasca h 19
Terreno PAR18T M2
Parete PAR18P M2

Lampada
Terreno PAR5T M2
Parete PAR5P M2

Decoro Parziale - Partial Decoration

Si aggiunge al codice dell'articolo bianco il codice relativo alla decorazione scelta.

Add to the white article item the code of the decoration chosen

Accessori abbinati - Coupled accessories



Croce
C15 M2
C20 M2

Ovale
CO8 M2
CO9 M2
CO11 M2
CO13 M2

Rettagonale
CR9 M2
CR10 M2
CR11 M2
CR13 M2



Linea Park

Carrara integrale

Vaso h 21
Terreno PAR20T M2X
Parete PAR20P M2X

Vaso h 27
Terreno PAR30T M2X

Vasca h 19
Terreno PAR18T M2X
Parete PAR18P M2X

Lampada
Terreno PAR5T M2X
Parete PAR5P M2X

Decoro Integrale - Full Decoration

Si aggiunge al codice dell'articolo bianco il codice relativo alla decorazione scelta più la lettera X

Add to the white article item the code of the decoration chosen plus the letter X

Accessori abbinati - Coupled accessories



Croce
C15 M2X
C20 M2X

Ovale
CO8 M2X
CO9 M2X
CO11 M2X
CO13 M2X

Rettagonale
CR9 M2X
CR10 M2X
CR11 M2X
CR13 M2X

- M1 Travertino
- M2 Carrara
- M3 Verde Alpi
- M4 Botticino
- M5 Nero Africa
- M6 Rosa Portogallo
- M7 Rosa Beta
- M11 Statuario
- M12 Rosa Porrino
- M13 Turkey



Scelta completa delle decorazioni disponibili a pag. 183
Complete decorations choice on page 183

Linea Park

Bianco con Greca 21



Vaso h 21

Terreno PAR20T Gre11
Parete PAR20P Gre11

Vaso h 27

Terreno PAR30T Gre11

Vasca h 19

Terreno PAR18T Gre11
Parete PAR18P Gre11

Lampada

Terreno PAR5T Gre11
Parete PAR5P Gre11

Bianco con Greca - White with Fret

Specificare il codice della combinazione con greca scelta
Scelta combinazioni con Greche a pag. 183

Indicate the code of the chosen combination of fret
Combinations with Frets sorting on page 183

Accessori abbinati - Coupled accessories



Croce

C15 Gre11
C20 Gre11

Ovale

CO8 Gre11
CO9 Gre11
CO11 Gre11
CO13 Gre11

Rettagonolare

CR9 Gre11
CR10 Gre11
CR11 Gre11
CR13 Gre11

Linea Park

Decorato con Greca 07



Vaso h 21

Terreno PAR20T Gre04
Parete PAR20P Gre04

Vaso h 27

Terreno PAR30T Gre04

Vasca h 19

Terreno PAR18T Gre04
Parete PAR18P Gre04

Lampada

Terreno PAR5T Gre04
Parete PAR5P Gre04

Decorato con Greca - Decorated with Fret

Specificare il codice della combinazione con greca scelta
Scelta combinazioni con Greche a pag. 183

Indicate the code of the chosen combination of fret
Combinations with Frets sorting on page 183

Accessori abbinati - Coupled accessories



Croce

C15 Gre04
C20 Gre04

Ovale

CO8 Gre04
CO9 Gre04
CO11 Gre04
CO13 Gre04

Rettagonolare

CR9 Gre04
CR10 Gre04
CR11 Gre04
CR13 Gre04

Linea **Camelia**



Vaso h 22 Terreno CAM20T
Parete CAM20P

Vaso h 29 Terreno CAM30T

Vasca h 18 Terreno CAM18T
Parete CAM18P

Lampada Terreno CAM5T
Parete CAM5P

Accessori abbinati - *Coupled accessories*

Croce
Cross

Art. - Item	Misura - Size
C15	cm 15 x 9
C20	cm 20 x 11



Cornice Ovale
Oval Frame

Art. - Item	Misura - Size
CO8	cm 8 x 10
CO9	cm 9 x 12
CO11	cm 11 x 15
CO13	cm 13 x 18



Cornice Rettangolare
Rectangular Frame

Art. - Item	Misura - Size
CR9	cm 9 x 12
CR10	cm 10 x 15
CR11	cm 11 x 15
CR13	cm 13 x 18



Linea Camelia

Botticino parziale



Vaso h 22
Terreno CAM20T M4
Parete CAM20P M4

Vaso h 29
Terreno CAM30T M4

Vasca h 18
Terreno CAM18T M4
Parete CAM18P M4

Lampada
Terreno CAM5T M4
Parete CAM5P M4

Decoro Parziale - Partial Decoration

Si aggiunge al codice dell'articolo bianco il codice relativo alla decorazione scelta.

Add to the white article item the code of the decoration chosen

Accessori abbinati - Coupled accessories



Croce
C15 M4
C20 M4

Ovale
CO8 M4
CO9 M4
CO11 M4
CO13 M4

Rettangolare
CR9 M4
CR10 M4
CR11 M4
CR13 M4

Linea Camelia

Botticino integrale



Vaso h 22
Terreno CAM20T M4X
Parete CAM20P M4X

Vaso h 29
Terreno CAM30T M4X

Vasca h 18
Terreno CAM18T M4X
Parete CAM18P M4X

Lampada
Terreno CAM5T M4X
Parete CAM5P M4X

Decoro Integrale - Full Decoration

Si aggiunge al codice dell'articolo bianco il codice relativo alla decorazione scelta più la lettera X

Add to the white article item the code of the decoration chosen plus the letter X

Accessori abbinati - Coupled accessories



Croce
C15 M4X
C20 M4X

Ovale
CO8 M4X
CO9 M4X
CO11 M4X
CO13 M4X

Rettangolare
CR9 M4X
CR10 M4X
CR11 M4X
CR13 M4X

- | | | | | | | | | | |
|-------------------------|----------------------|-------------------------|------------------------|--------------------------|------------------------------|------------------------|-------------------------|----------------------------|----------------------|
| M1
Travertino | M2
Carrara | M3
Verde Alpi | M4
Botticino | M5
Nero Africa | M6
Rosa Portogallo | M7
Rosa Beta | M11
Statuario | M12
Rosa Porrino | M13
Turkey |
|-------------------------|----------------------|-------------------------|------------------------|--------------------------|------------------------------|------------------------|-------------------------|----------------------------|----------------------|



Scelta completa delle decorazioni disponibili a pag. 183
Complete decorations choice on page 183

Linea Camelia

Orchidea



Vaso h 22
Terreno CAM20T Orc
Parete CAM20P Orc

Vaso h 29
Terreno CAM30T Orc

Vasca h 18
Terreno CAM18T Orc
Parete CAM18P Orc

Lampada
Terreno CAM5T Orc
Parete CAM5P Orc

Decoro Orchidea - *Orchidea Decoration*

Accessori abbinati - *Coupled accessories*



Croce
C15 Orc
C20 Orc

Ovale
CO8 Orc
CO9 Orc
CO11 Orc
CO13 Orc

Rettangolare
CR9 Orc
CR10 Orc
CR11 Orc
CR13 Orc

Linea Camelia

Linaria



Vaso h 22
Terreno CAM20T Lin
Parete CAM20P Lin

Vaso h 29
Terreno CAM30T Lin

Vasca h 18
Terreno CAM18T Lin
Parete CAM18P Lin

Lampada
Terreno CAM5T Lin
Parete CAM5P Lin

Decoro Linaria - *Linaria Decoration*

Accessori abbinati - *Coupled accessories*



Croce
C15 Lin
C20 Lin

Ovale
CO8 Lin
CO9 Lin
CO11 Lin
CO13 Lin

Rettangolare
CR9 Lin
CR10 Lin
CR11 Lin
CR13 Lin

Linea Garden



Vaso h 21 Terreno GAR20T
Parete GAR20P

Vaso h 29 Terreno GAR30T

Vasca h 18 Terreno GAR18T
Parete GAR18P

Lampada Terreno GAR5T
Parete GAR5P

Accessori abbinati - *Coupled accessories*

Croce
Cross

Art. - Item	Misura - Size
GARC15	cm 15 x 9
GARC20	cm 20 x 11



Cornice Ovale
Oval Frame

Art. - Item	Misura - Size
GARCO8	cm 8 x 10
GARCO9	cm 9 x 12
GARCO11	cm 11 x 15
GARCO13	cm 13 x 18



Cornice Rettangolare
Rectangular Frame

Art. - Item	Misura - Size
GARCR9	cm 9 x 12
GARCR10	cm 10 x 15
GARCR11	cm 11 x 15
GARCR13	cm 13 x 18



Linea Garden

Travertino parziale



Vaso h 21
Terreno GAR20T M1
Parete GAR20P M1

Vaso h 29
Terreno GAR30T M1

Vasca h 18
Terreno GAR18T M1
Parete GAR18P M1

Lampada
Terreno GAR5T M1
Parete GAR5P M1

Decoro Parziale - Partial Decoration

Si aggiunge al codice dell'articolo bianco il codice relativo alla decorazione scelta.

Add to the white article item the code of the decoration chosen

Accessori abbinati - Coupled accessories



Croce
GARC15 M1
GARC20 M1

Ovale
GARCO8 M1
GARCO9 M1
GARCO11 M1
GARCO13 M1

Rettangolare
GARCR9 M1
GARCR10 M1
GARCR11 M1
GARCR13 M1

Linea Garden

Travertino integrale



Vaso h 21
Terreno GAR20T M1X
Parete GAR20P M1X

Vaso h 29
Terreno GAR30T M1X

Vasca h 18
Terreno GAR18T M1X
Parete GAR18P M1X

Lampada
Terreno GAR5T M1X
Parete GAR5P M1X

Decoro Integrale - Full Decoration

Si aggiunge al codice dell'articolo bianco il codice relativo alla decorazione scelta più la lettera X

Add to the white article item the code of the decoration chosen plus the letter X

Accessori abbinati - Coupled accessories



Croce
GARC15 M1X
GARC20 M1X

Ovale
GARCO8 M1X
GARCO9 M1X
GARCO11 M1X
GARCO13 M1X

Rettangolare
GARCR9 M1X
GARCR10 M1X
GARCR11 M1X
GARCR13 M1X

- | | | | | | | | | | |
|-------------------------|----------------------|-------------------------|------------------------|--------------------------|------------------------------|------------------------|-------------------------|----------------------------|----------------------|
| M1
Travertino | M2
Carrara | M3
Verde Alpi | M4
Botticino | M5
Nero Africa | M6
Rosa Portogallo | M7
Rosa Beta | M11
Statuario | M12
Rosa Porrino | M13
Turkey |
|-------------------------|----------------------|-------------------------|------------------------|--------------------------|------------------------------|------------------------|-------------------------|----------------------------|----------------------|



Scelta completa delle decorazioni disponibili a pag. 183
Complete decorations choice on page 183



Linea Garden

Bianco con Immagine

Bianco con Immagine - White with Image

Specificare il numero dell' immagine scelta.
Indicate the number of the chosen image

Es. GAR20T IM21

Vaso h 21
Terreno GAR20T IM
Parete GAR20P IM

Vaso h 29
Terreno GAR30T IM

Vasca h 18
Terreno GAR18T IM
Parete GAR18P IM

Lampada
Terreno GAR5T IM
Parete GAR5P IM



Linea Garden

Decorato con Immagine

Decorato con Immagine - Decorated with Image

Specificare il numero dell' immagine scelta ed il codice della decorazione scelta.

Indicate the number of the chosen image and the code of the chosen decoration.

Es. GAR30T IM50 M1

Vaso h 21
Terreno GAR20T IMX
Parete GAR20P IMX

Vaso h 29
Terreno GAR30T IMX

Vasca h 18
Terreno GAR18T IMX
Parete GAR18P IMX

Lampada
Terreno GAR5T IMX
Parete GAR5P IMX

Linea Dalia



Lampada Parete DAL5P

Vasca h 18 Parete DAL18P

Accessori abbinati - Coupled accessories

Croce Cross

Art. - Item	Misura - Size
C15	cm 15 x 9
C20	cm 20 x 11



Cornice Ovale Oval Frame

Art. - Item	Misura - Size
CO8	cm 8 x 10
CO9	cm 9 x 12
CO11	cm 11 x 15
CO13	cm 13 x 18



Cornice Rettangolare Rectangular Frame

Art. - Item	Misura - Size
CR9	cm 9 x 12
CR10	cm 10 x 15
CR11	cm 11 x 15
CR13	cm 13 x 18





Linea Dalia

Botticino parziale

Lampada
Parete DAL5P M4

Vasca h 18
Parete DAL18P M4

Decoro Parziale - Partial Decoration

Si aggiunge al codice dell'articolo bianco il codice relativo alla decorazione scelta.

Add to the white article item the code of the decoration chosen

Accessori abbinati - Coupled accessories



Croce
C15 M4
C20 M4

Ovale
CO8 M4
CO9 M4
CO11 M4
CO13 M4

Rettangolare
CR9 M4
CR10 M4
CR11 M4
CR13 M4



Linea Dalia

Botticino integrale

Lampada
Parete DAL5P M4X

Vasca h 18
Parete DAL18P M4X

Decoro Integrale - Full Decoration

Si aggiunge al codice dell'articolo bianco il codice relativo alla decorazione scelta più la lettera X

Add to the white article item the code of the decoration chosen plus the letter X

Accessori abbinati - Coupled accessories



Croce
C15 M4X
C20 M4X

Ovale
CO8 M4X
CO9 M4X
CO11 M4X
CO13 M4X

Rettangolare
CR9 M4X
CR10 M4X
CR11 M4X
CR13 M4X

- M1 Travertino
- M2 Carrara
- M3 Verde Alpi
- M4 Botticino
- M5 Nero Africa
- M6 Rosa Portogallo
- M7 Rosa Beta
- M11 Statuario
- M12 Rosa Porrino
- M13 Turkey



Scelta completa delle decorazioni disponibili a pag. 183
Complete decorations choice on page 183



Linea Dalia

Girasole

Lampada
Parete DAL5P Gir

Vasca h 18
Parete DAL18P Gir

Decoro Girasole - *Girasole Decoration*

Accessori abbinati - *Coupled accessories*



Croce
C15 M4X
C20 M4X

Ovale
CO8 M4X
CO9 M4X
CO11 M4X
CO13 M4X

Rettagonolare
CR9 M4X
CR10 M4X
CR11 M4X
CR13 M4X



Linea Dalia

Decorato con Greca

Lampada
Parete DAL5P Gre04

Vasca h 18
Parete DAL18P Gre04

Decorato con Greca - *Decorated with Fret*

Specificare il codice della combinazione con greca scelta
Scelta combinazioni con Greche a pag. 183

Indicate the code of the chosen combination of fret
Combinations with Frets sorting on page 183

Accessori abbinati - *Coupled accessories*



Croce
C15 Gre04
C20 Gre04

Ovale
CO8 Gre04
CO9 Gre04
CO11 Gre04
CO13 Gre04

Rettagonolare
CR9 Gre04
CR10 Gre04
CR11 Gre04
CR13 Gre04

Linea Ninfea



Vaso h 27 Terreno NIN30T

Vaso h 19,5 Terreno NIN20T
Parete NIN20P

Lampada Terreno NIN5T
Parete NIN5P

Vasca h 18 Terreno NIN18T
Parete NIN18P

Accessori abbinati - Coupled accessories

Croce Cross

Art. - Item	Misura - Size
C15	cm 15 x 9
C20	cm 20 x 11



Cornice Ovale Oval Frame

Art. - Item	Misura - Size
CO8	cm 8 x 10
CO9	cm 9 x 12
CO11	cm 11 x 15
CO13	cm 13 x 18



Cornice Rettangolare Rectangular Frame

Art. - Item	Misura - Size
CR9	cm 9 x 12
CR10	cm 10 x 15
CR11	cm 11 x 15
CR13	cm 13 x 18





Linea Ninfea

Rosa Portogallo parziale

Vaso h 27
Terreno NIN30T M6

Vaso h 19,5
Terreno NIN20T M6
Parete NIN20P M6

Lampada
Terreno NIN5T M6
Parete NIN5P M6

Vasca h 18
Terreno NIN18T M6
Parete NIN18P M6

Decoro Parziale - Partial Decoration

Si aggiunge al codice dell'articolo bianco il codice relativo alla decorazione scelta.

Add to the white article item the code of the decoration chosen

Accessori abbinati - Coupled accessories



Croce
C15 M6
C20 M6

Ovale
CO8 M6
CO9 M6
CO11 M6
CO13 M6

Rettagonolare
CR9 M6
CR10 M6
CR11 M6
CR13 M6



Linea Ninfea

Rosa Portogallo integrale

Vaso h 27
Terreno NIN30T M6X

Vaso h 19,5
Terreno NIN20T M6X
Parete NIN20P M6X

Lampada
Terreno NIN5T M6X
Parete NIN5P M6X

Vasca h 18
Terreno NIN18T M6X
Parete NIN18P M6X

Decoro Integrale - Full Decoration

Si aggiunge al codice dell'articolo bianco il codice relativo alla decorazione scelta più la lettera X

Add to the white article item the code of the decoration chosen plus the letter X

Accessori abbinati - Coupled accessories



Croce
C15 M6X
C20 M6X

Ovale
CO8 M6X
CO9 M6X
CO11 M6X
CO13 M6X

Rettagonolare
CR9 M6X
CR10 M6X
CR11 M6X
CR13 M6X

- | | | | | | | | | | |
|-------------------------|----------------------|-------------------------|------------------------|--------------------------|------------------------------|------------------------|-------------------------|----------------------------|----------------------|
| M1
Travertino | M2
Carrara | M3
Verde Alpi | M4
Botticino | M5
Nero Africa | M6
Rosa Portogallo | M7
Rosa Beta | M11
Statuario | M12
Rosa Porrino | M13
Turkey |
|-------------------------|----------------------|-------------------------|------------------------|--------------------------|------------------------------|------------------------|-------------------------|----------------------------|----------------------|



Scelta completa delle decorazioni disponibili a pag. 183
Complete decorations choice on page 183

Linea Ninfea

Bianco con Greca 09



Vaso h 27
Terreno NIN30T Gre07

Vaso h 19,5
Terreno NIN20T Gre07
Parete NIN20P Gre07

Lampada
Terreno NIN5T Gre07
Parete NIN5P Gre07

Vasca h 18
Terreno NIN18T Gre07
Parete NIN18P Gre07

Bianco con Greca - White with Fret

Specificare il codice della combinazione con greca scelta
Scelta combinazioni con Greche a pag. 183

Indicate the code of the chosen combination of fret
Combinations with Frets sorting on page 183

Accessori abbinati - Coupled accessories



Croce
C15 Gre07
C20 Gre07

Ovale
CO8 Gre07
CO9 Gre07
CO11 Gre07
CO13 Gre07

Rettagonale
CR9 Gre07
CR10 Gre07
CR11 Gre07
CR13 Gre07

Linea Ninfea

Decorato con Greca 21



Vaso h 27
Terreno NIN30T Gre12

Vaso h 19,5
Terreno NIN20T Gre12
Parete NIN20P Gre12

Lampada
Terreno NIN5T Gre12
Parete NIN5P Gre12

Vasca h 18
Terreno NIN18T Gre12
Parete NIN18P Gre12

Decorato con Greca - Decorated with Fret

Specificare il codice della combinazione con greca scelta
Scelta combinazioni con Greche a pag. 183

Indicate the code of the chosen combination of fret
Combinations with Frets sorting on page 183

Accessori abbinati - Coupled accessories



Croce
C15 Gre12
C20 Gre12

Ovale
CO8 Gre12
CO9 Gre12
CO11 Gre12
CO13 Gre12

Rettagonale
CR9 Gre12
CR10 Gre12
CR11 Gre12
CR13 Gre12



Lettere in Porcellana - Porcelain Letters

Articolo - Item			Descrizione - Description
Bianco	Decorato	Oro Zecchino	
L40	L40D	L300	Lettere h cm 4
L30	L30D	L300	Numeri h cm 3
LV	LVD	LVO	Punteggiatura

Le lettere possono essere fornite con o senza perni.
 We can supply the letters with or without the screws on the back

A B C D E F G H I L M N O P Q R S T U V Z W X J K Y
0 1 2 3 4 5 6 7 8 9 N M . , - ^ * †



M01



M02



M03



M04



M01D



M02D



M03D



M04D

Targa Immagine - Image Plaque

Articolo - Item		Misure - Size
Bianco	Decorato	cm
M01	M01D	15 x 11
M02	M02D	15 x 12
M03	M03D	16,5 x 16,5
M04	M04D	18,5 x 18,5

Accessori in Porcellana

Lettere e Targhe

Decorazioni disponibili per Fotoceramiche e Vasi - Available decorations for photoceramics and Vases



M1 Travertino



M2 Carrara



M3 Verde Alpi



M4 Botticino



M5 Nero Africa



M6 Rosa Portogallo



M7 Rosa Beta



M8 Rilievo Grigio



M9 Rilievo Beige



M10 Rilievo Rosa



M11 Statuario



M12 Rosa Porrino



M13 Turkey

Combinazioni Greche per Vasi - Combination of Frets for Vases



art. Gre01
Greca 05
su fondo bianco

art. Gre02
Greca 05
su Botticino M4

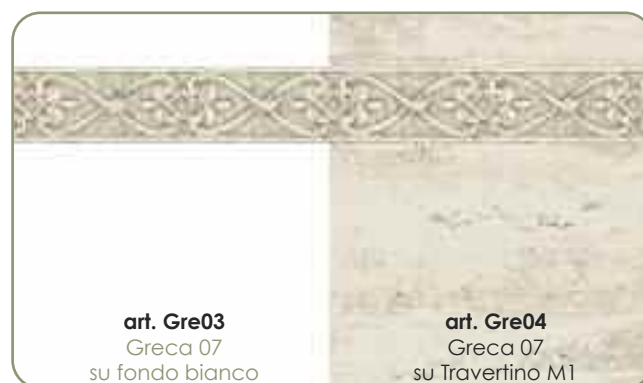

art. Gre03
Greca 07
su fondo bianco

art. Gre04
Greca 07
su Travertino M1



art. Gre05
Greca 07
su fondo bianco

art. Gre06
Greca 07
su Rosa Portogallo M6



art. Gre07
Greca 09
su fondo bianco

art. Gre08
Greca 09
su Carrara M2



art. Gre09
Greca 12
su fondo bianco

art. Gre10
Greca 12
su Carrara M2



art. Gre11
Greca 21
su fondo bianco

art. Gre12
Greca 21
su Travertino M1

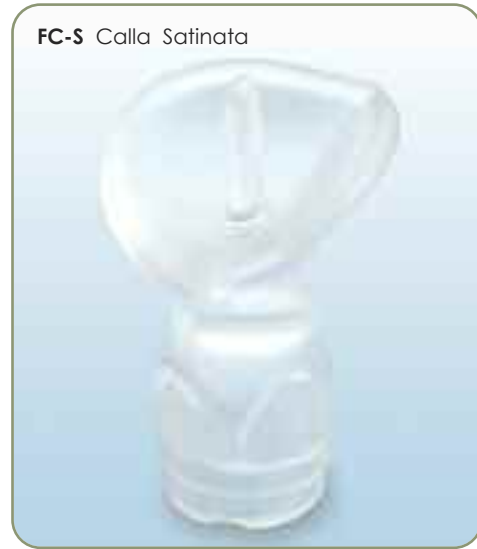
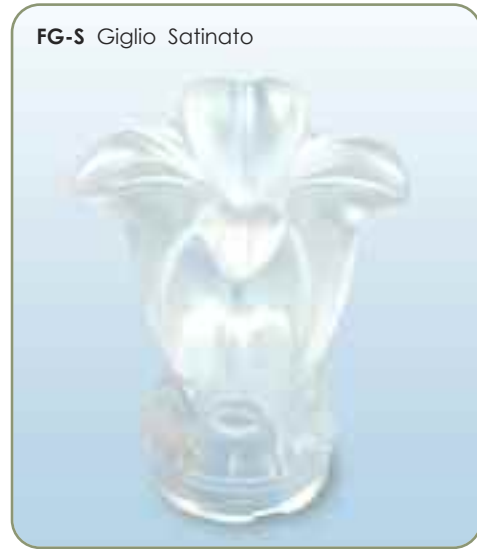
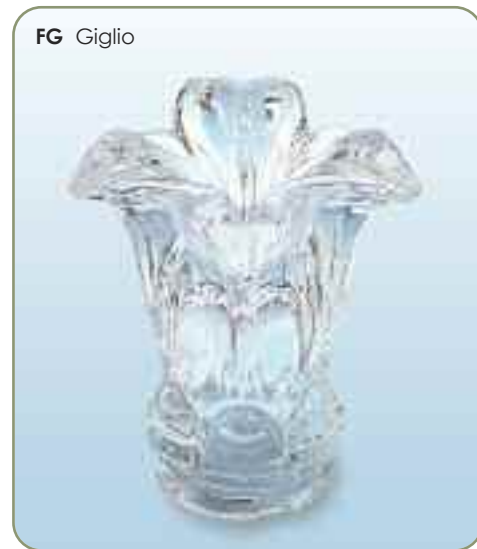
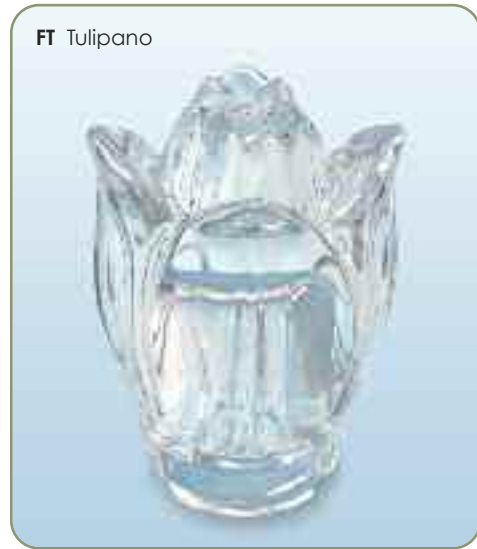
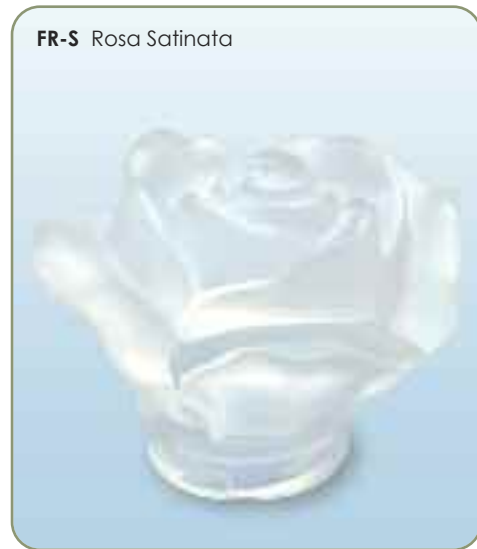
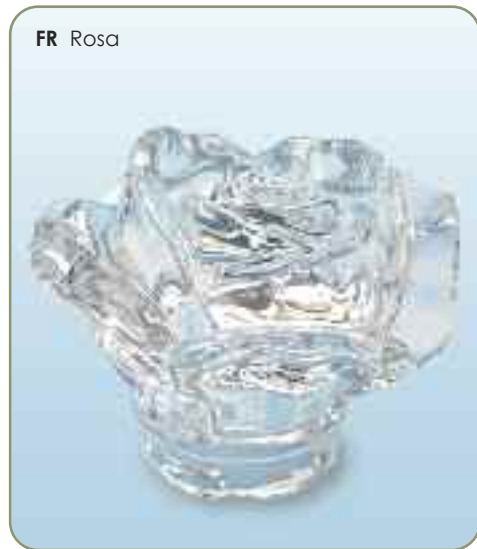

Accessori

Fiamme in Cristallo

Fiamme in cristallo per lampade *Crystals for lamps*

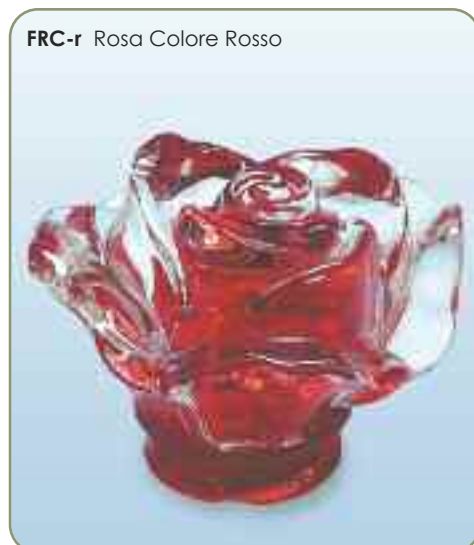

Accessori

Fiamme in Cristallo **Colorate**

La dotazione standard per gli accessori comprende l' interno in plastica per Vasi e Vaschette e la ghiera inox per le Lampade
The vases have a plastic flowers container as per standard equipment.

Interni inox - *Inox flowers container*

Articolo - Item	Descrizione - Description
I20	Interno Inox per Vaso h 20
I30	Interno Inox per Vaso h 30
I18	Interno Inox per Vasca h 18
IP18	Interno Plastica con ghiera inox per Vasca h 18



I20 Interno Inox per Vaso h 20



I30 Interno Inox per Vaso h 30



IP18 Interno Plastica con ghiera inox per Vasca h 18



I18 Interno Inox per Vasca h 18

Accessori

Interni

Il profondo rinnovamento stilistico operato sull'intera gamma dei nostri prodotti non esclude le **Urne in Porcellana** che vengono aggiornate e rivisitate secondo i nuovi dettami stilistici di eleganza e sobrietà. Novità assoluta anche nella collezione di urne é la "**Linea Liberty**" che si unisce alle già note linee Sfera - Classica - Esagono.

Anche per le urne, Polistampa si impegna a spedire la merce in **24 ore** dall'acquisizione dell'ordine.

*The profound renewal stylistic operated on the full range of our products does not exclude the **Porcelain Urns** that are updated and revised according to the new traditions of elegance and sobriety. Absolute novelty also in collection of the Urns is the "**Liberty Line**" that joins the already known lines Sphere-Classic-Hexagon.*

*Also for urns Polistampa commits to send the goods within **24 hours** after acquisition of the order.*

PORCELAIN URNES

URNE IN PORCELLANA

Linea Liberty

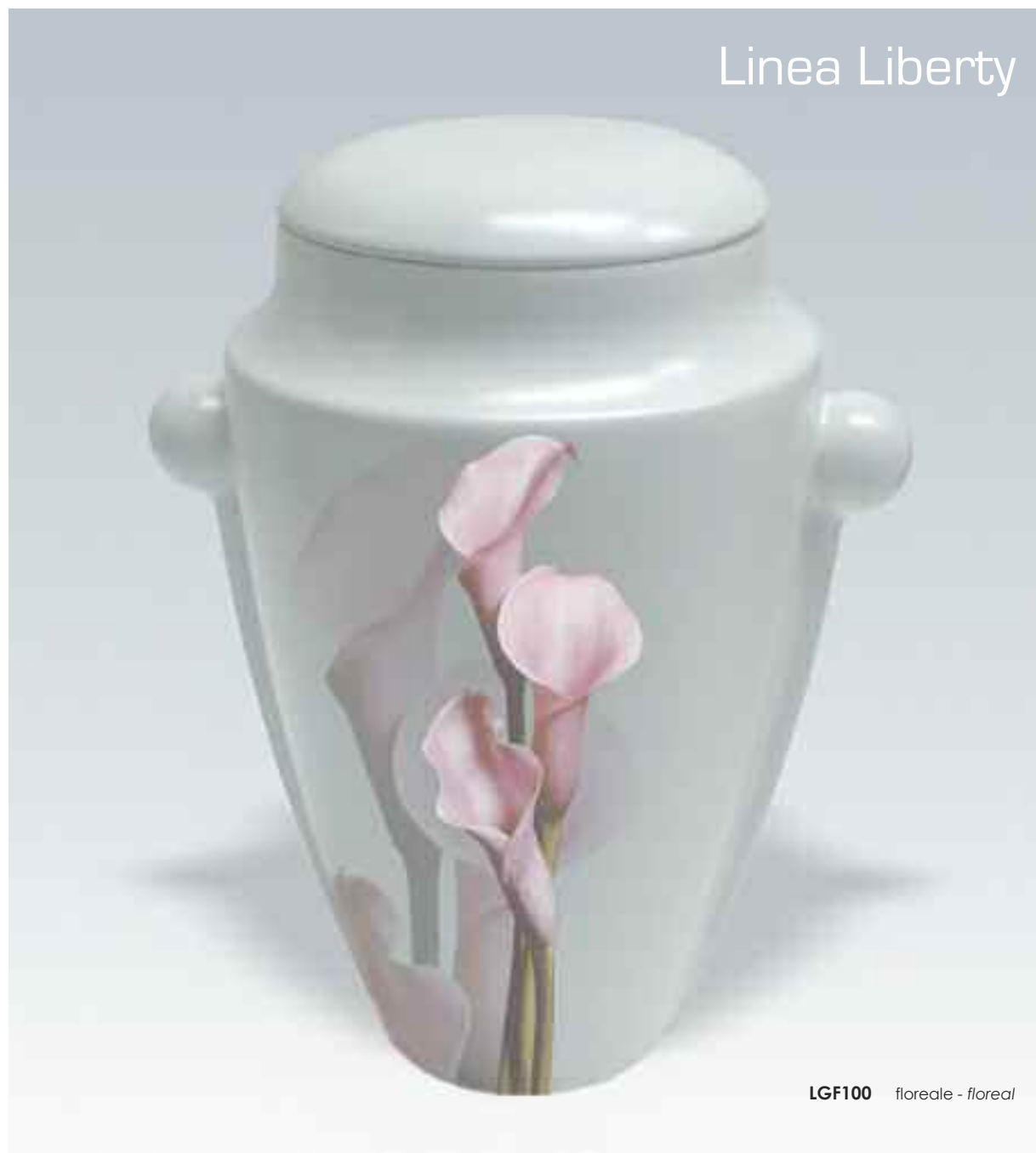

LGF100 floreale - floreal



LGF101 angelo - angel



LGF102 alcea - alcea

Urna Grande - Big Urn

Articolo - Item	Capacità -Capacity	Misure -Size
LG	cm3 4000	cm (H x L) 30 x 22



Apertura dall'alto
Opening from the top

Chiusura ermetica a richiesta
Watertight closing on demand

Urne in Porcellana

Linea **Liberty**



LGF103 floreale - floreal



LGF104 floreale - floreal



LGF105 floreale - floreal



LGF106 floreale - floreal



LGF107 floreale - floreal



LGF108 floreale - floreal

Urne in Porcellana

Linea **Liberty**



LGF109 *Madonna - Our Lady*



LGF110 *Cristo - Christ*

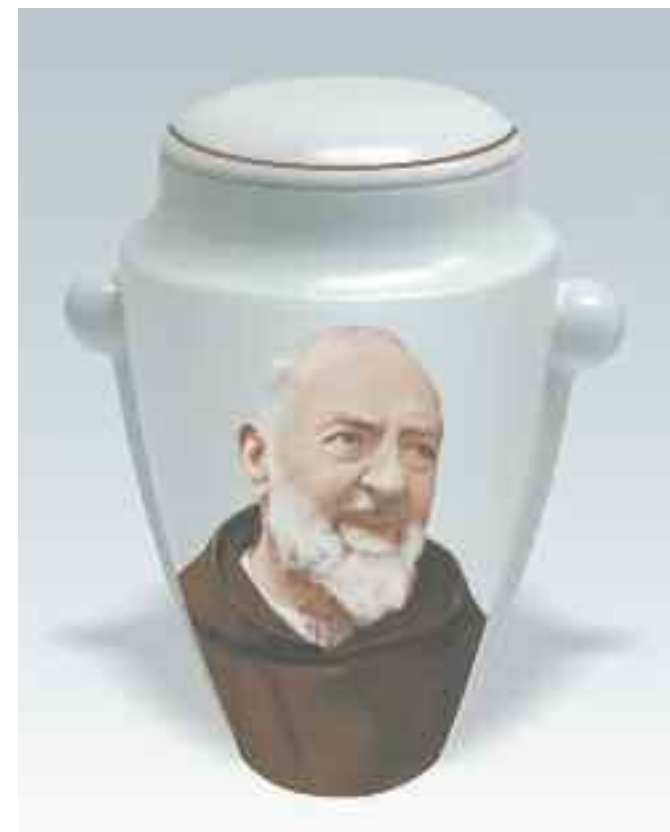

LGF111 *S. Pio - S. Pio*



LGF112 *Papa - Pope*



LGF113 *genziana - genziana*



LGF114 *oro/azzurro - gold/azure*

Urne in Porcellana

Linea **Liberty**

Linea Sfera

Grande - Big **SGF115** floreale - Floreal
Piccola - Small **SPF115** floreale - Floreal



Urna Grande - Big Urn

Articolo - Item	Capacità -Capacity	Misure -Size
SG	cm3 4.000	cm (H x L) 21 x 21



Apertura dall'alto
Opening from the top

Chiusura ermetica a richiesta
Watertight closing on demand

Urna Piccola - Small Urn

Articolo - Item	Capacità -Capacity	Misure -Size
SP	cm3 500	cm (H x L) 11 x 11



Apertura dal basso
Opening from the bottom

Chiusura ermetica inclusa
Watertight closing included

Urne in Porcellana

Linea **Sfera**



Grande - Big **SGF116** floreale - floreal
Piccola - Small **SPF116** floreale - floreal



Grande - Big **SGF117** floreale - floreal
Piccola - Small **SPF117** floreale - floreal



Grande - Big **SGF118** floreale - floreal
Piccola - Small **SPF118** floreale - floreal



Grande - Big **SGF119** floreale - floreal
Piccola - Small **SPF119** floreale - floreal



Grande - Big **SGF120** floreale - floreal
Piccola - Small **SPF120** floreale - floreal



Grande - Big **SGF121** floreale - floreal
Piccola - Small **SPF121** floreale - floreal

Urne in Porcellana

Linea **Sfera**



Grande - Big **SG01** verde artistico - artistic green
Piccola - Small **SP01** verde artistico - artistic green



Grande - Big **SG02** bianco opaco - mat white
Piccola - Small **SP02** bianco opaco - mat white



Grande - Big **SG03** bianco lucido - glossy white
Piccola - Small **SP03** bianco lucido - glossy white



Grande - Big **SG04** oro zecchino - pure gold
Piccola - Small **SP04** oro zecchino - pure gold



Grande - Big **SG06** blu opaco - mat blue
Piccola - Small **SP06** blu opaco - mat blue



Grande - Big **SG07** marrone artistico - artistic brown
Piccola - Small **SP07** marrone artistico - artistic brown

Urne in Porcellana

Linea **Sfera**

Linea Classica

Grande - Big **CG10** rilievo beige/oro - beige relief/gold
Piccola - Small **CP10** rilievo beige/oro - beige relief/gold

A richiesta è possibile decorare il modello CG10 con rilievo grigio e filo argento
 On demand we can decorate the item CG10 with a grey relief and silver line



Urna Grande - Big Urn

Articolo - Item	Capacità -Capacity	Misure -Size
CG	cm3 5.000	cm (H x L) 24 x 21

Urna Piccola - Small Urn

Articolo - Item	Capacità -Capacity	Misure -Size
CP	cm3 600	cm (H x L) 12 x 10



Apertura dall'alto
 Opening from the top
 Chiusura ermetica a richiesta
 Watertight closing on demand



Apertura dal basso
 Opening from the bottom
 Chiusura ermetica inclusa
 Watertight closing included

Urne in Porcellana

Linea **Classica**



Grande - Big **CG11** bianco opaco - mat white
Piccola - Small **CP11** bianco opaco - mat white



Grande - Big **CG15** ghirlanda - garland
Piccola - Small **CP15** ghirlanda - garland



Grande - Big **CG17** foglie di vite - vine leaves
Piccola - Small **CP17** foglie di vite - vine leaves



Grande - Big **CG18** fiori a rilievo - relief flowers
Piccola - Small **CP18** fiori a rilievo - relief flowers



Grande - Big **CG20** blu opaco/oro - mat blue/gold
Piccola - Small **CP20** blu opaco/oro - mat blue/gold



Grande - Big **CG21** bianco opaco/oro - mat white/gold
Piccola - Small **CP21** bianco opaco/oro - mat white/gold



Grande - Big **CG22** oro/azzurro - gold/azure
Piccola - Small **CP22** oro/azzurro - gold/azure



Grande - Big **CG23** triangoli oro - gold triangles
Piccola - Small **CP23** triangoli oro - gold triangles



Grande - Big **CG25** bolle platino - platinum bubbles
Piccola - Small **CP25** bolle platino - platinum bubbles

Urne in Porcellana

Linea **Classica**



Grande - Big **CG26** oro/avorio - gold/ivory
Piccola - Small **CP26** oro/avorio - gold/ivory



Grande - Big **CG28** portoro - portoro
Piccola - Small **CP28** portoro - portoro



Grande - Big **CG29** blu/bolle oro - blue/gold bubbles
Piccola - Small **CP29** blu/bolle oro - blue/gold bubbles



Grande - Big **CGF122** Angeli - Angels



Grande - Big **CGF123** Madonna - Our Lady



Grande - Big **CGF124** Madonna - Our Lady



Grande - Big **CGF125** Angelo - Angel



Grande - Big **CGF126** Madonna con Gesù - Our Lady with Jesus



TAPPO CON IMMAGINE - LID WITH IMAGE
Grande - Big **CGF127** Madonna - Our Lady

Urne in Porcellana

Scelta Immagini da inserire sul modello CGF127 a pag. 150 Images sorting to put on the model CGF127 on page 150

Linea **Classica**

Linea Esagono

Grande - Big EGF128 floreale - floreal
Piccola - Small EPF128 floreale - floreal



Urna Grande - Big Urn

Articolo - Item	Capacità -Capacity	Misure -Size
EG	cm3 5.000	cm (H x L) 23 x 26



Apertura dal basso
Opening from the bottom
 Chiusura ermetica inclusa
Watertight closing included

Urna Piccola - Small Urn

Articolo - Item	Capacità -Capacity	Misure -Size
EP	cm3 335	cm (H x L) 12 x 11



Apertura dal basso
Opening from the bottom
 Chiusura ermetica inclusa
Watertight closing included

Urne in Porcellana

Linea **Esagono**



Grande - Big **EGF129** floreale - floreal
Piccola - Small **EPF129** floreale - floreal



Grande - Big **EGF130** floreale - floreal
Piccola - Small **EPF130** floreale - floreal



Grande - Big **EGF131** floreale - floreal
Piccola - Small **EPF131** floreale - floreal



Grande - Big **EGF132** floreale - floreal
Piccola - Small **EPF132** floreale - floreal



Grande - Big **EGF133** floreale - floreal
Piccola - Small **EPF133** floreale - floreal



Grande - Big **EGF134** Madonna - Our Lady
Piccola - Small **EPF134** Madonna - Our Lady



Grande - Big **EGF135** Cristo - Christ
Piccola - Small **EPF135** Cristo - Christ



Grande - Big **EGF136** Angelo - Angel
Piccola - Small **EPF136** Angelo - Angel



Grande - Big **EG36** bianco/oro - white/gold
Piccola - Small **EP36** bianco/oro - white/gold

Urne in Porcellana

Linea Esagono



Grande - Big **EG30** botticino e greca - *botticino and fret*
Piccola - Small **EP30** botticino e greca - *botticino and fret*



Grande - Big **EG33** angeli - *angels*
Piccola - Small **EP33** angeli - *angels*



Grande - Big **EG37** pietra viola/oro - *violet stone/gold*
Piccola - Small **EP37** pietra viola/oro - *violet stone/gold*



Grande - Big **EG38** triangoli oro - *gold triangles*
Piccola - Small **EP38** triangoli oro - *gold triangles*



Grande - Big **EG40** rosa/oro - *pink/gold*
Piccola - Small **EP40** rosa/oro - *pink/gold*



Grande - Big **EG41** oro/avorio - *gold/ivory*
Piccola - Small **EP41** oro/avorio - *gold/ivory*



Grande - Big **EG42** oro/azzurro - *gold/azure*
Piccola - Small **EP42** oro/azzurro - *gold/azure*



Grande - Big **EG44** blu/bolle oro - *blue/gold bubbles*
Piccola - Small **EP44** blu/bolle oro - *blue/gold bubbles*



Grande - Big **EG45** rilievo beige - *beige relief*
Piccola - Small **EP45** rilievo beige - *beige relief*

Urne in Porcellana

Linea Esagono

A richiesta è possibile decorare il modello EG45 con rilievo grigio e filo argento
On demand we can decorate the item EG45 with a grey relief and silver line



Urna Classica personalizzata

Personalized Classic Urn

CGIM Grande

CPIM Piccola

E' possibile personalizzare l'urna Classica grande e piccola con foto e scritte fornite dal cliente.

CGIM Big

CPIM Small

It's possible to personalize the big and small Classic urn with photoes and writings supplied from the client.



Urna Esagono personalizzata

Personalized Hexagon Urn

EGIM Grande

EPIM Piccola

E' possibile personalizzare l'urna Esagono grande e piccola con foto e scritte fornite dal cliente.

EGIM Big

EPIM Small

It's possible to personalize the big and small Hexagon urn with photoes and writings supplied from the client.



Urna Liberty personalizzata

Personalized Liberty Urn

LGIM

E' possibile personalizzare l'urna Liberty con foto e scritte fornite dal cliente.

LGIM

It's possible to personalize the Liberty urn with photoes and writings supplied from the client.

Urne in Porcellana

Urna Personalizzata

Sicurezza Urne



La nostra chiusura ermetica, come da normativa è predisposta per il sigillo dell'urna.

Our watertight closing, as per regulation, is prepared to seal the urn.



A richiesta, l'urna puo' essere fornita con sacchetto in plastica e fascetta di chiusura.

On demand, the urn can be supplied with a small plastic bag and a little closing band.

Polistampa Linea Decalco s.r.l.

S.P. Quartaccio Km. 4,600

01034 Fabrica di Roma (VT)

Tel. 0761.598153 Fax 0761.549293

www.polistampa.it

lapidi@polistampa.net